

36 (1.4')

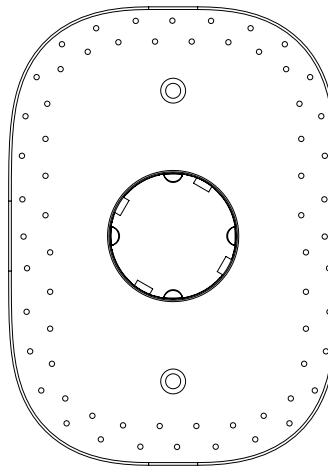

83
(3.3')

131
(5')

94 (3.7')



17.5
(0.7')

RECEPTACLES: one

INSTALLATION: mud-in

MATERIALS: polycarbonate casing,
electrical components.

CONFIGURATION: single outlets

DESCRIPTION

The 22 is a complete suite of interior wall accessories that challenge the traditional, tired and ubiquitous cover plate concept. The 22 is designed to "mud" directly into drywall without a visible cover plate or trim. Alternatively, it may be set flush into millwork, marble, glass or any other wall surface. 22 operative components include: power outlets, data/telephone receptacles, cable connectors, line voltage on/off switches, and low voltage intelligent controls.

APPLICATIONS

The 22.2 system is a departure from conventional cover plate systems and requires precise and skilled craftsmanship during installation. Switches and power receptacles can now be flush with the wall surface and are visually more subtle than ever before.

NOTES

+ All tamper resistant components are sold as assemblies.

Worldwide utility patents pending.
US patent # 7,956,295 B2

For additional information, please contact:

BOCCI Vancouver
info@bocci.ca
www.bocci.ca

BOCCI Berlin
europe@bocci.ca
www.bocci.ca

22.2.1

Design by Omer Arbel
PRODUCT SPECIFICATION

© 2014, Bocci Design and Manufacturing Inc. Any inquiries should be directed to the following email address: info@bocci.ca.

BOCCI

The 22 system is a departure from conventional cover plate systems, and requires precise and skilled craftsmanship during installation. If you have never installed a 22, bocci recommends a practice installation.

1

1.5mm
(1/16")

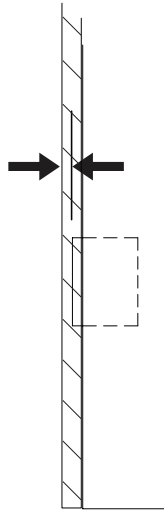

For optimum strength, make sure the back of the mounting plate meets the junction box (the surface of the junction box must be approx. 1.5mm or 1/16" back from face of drywall). If there is no direct contact between the back of the mounting plate and the junction box, the system will perform, but not at its peak strength.

2

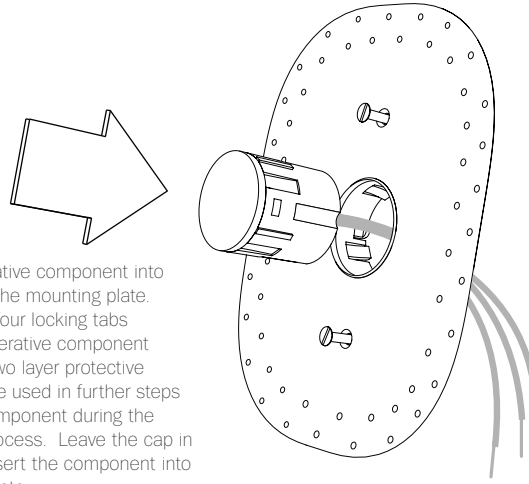

Insert the operative component into the opening in the mounting plate. Ensure that all four locking tabs engage. The operative component comes with a two layer protective cap. This will be used in further steps to mask the component during the "mudding in" process. Leave the cap in place as you insert the component into the mounting plate.

3

Connect the wires according to the wiring diagram below using appropriately sized marettes. These instructions are to be used generally for outlets. For alternate receptacles, please see specific installation sheets for wiring instructions.

Note:

22 tamper-resistant receptacles use 12 Ga (2.63 mm) wire.

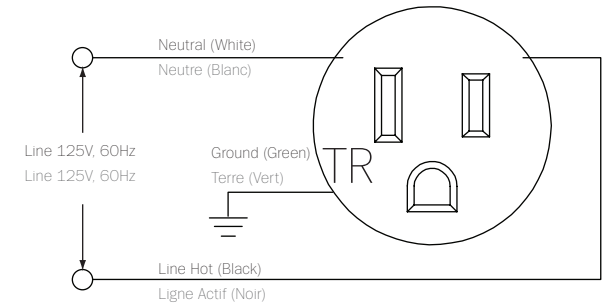

4

Fasten the mounting plate to the junction box using the screws provided.

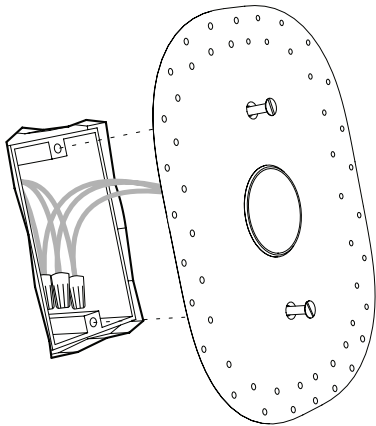

5

Tape the mounting plate edges with fiber mesh drywall tape.

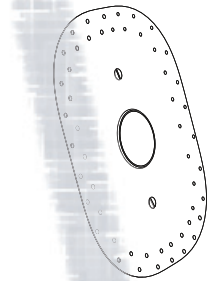

6

Use a drywall filler compound to "mud over" the entire assembly - feather from the center of the mounting plate outwards using a large drywall trowel.

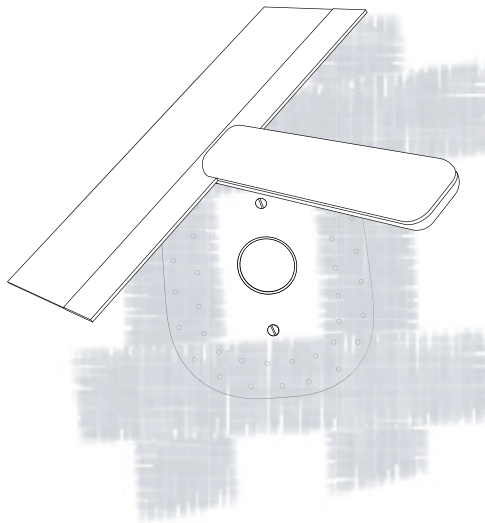

7

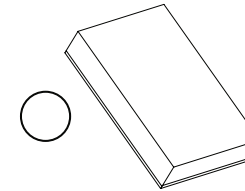

Using a foam sanding block, sand entire area until the rim and the protective cap of the operative component are exposed. For long term performance, it is essential that mud is sanded right down to the plastic rim.

8

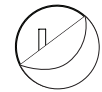

partially peel back paper face of protective cap ensuring silicon layer remains snugly in place around operative component. This will allow you to locate the component after painting.

9

Paint over entire assembly.

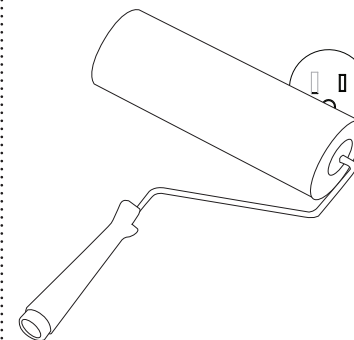

10

Once dry, peel entire paper face. A tab in the silicon layer of the protective cap will be exposed under the paper - this will allow you to remove the silicon layer and expose the operative component.

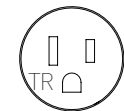

Purchase additional components at www.bocci.ca/22

US patent #7,956,295 & 8,232,482

For additional assistance:

BOCCI Vancouver
info@bocci.ca
www.bocci.ca

BOCCI Berlin
infoeu@bocci.ca
www.bocci.ca



© 2014, Bocci Design and Manufacturing Inc.
Any inquiries should be directed to the following email address: info@bocci.ca.

BOCCI

22.2.1 Design by Omer Arbel
INSTALLATION INSTRUCTIONS