

# Data Sheet

## GFEP Contactor Panel (Ground Fault Equipment Protection)

### General Information

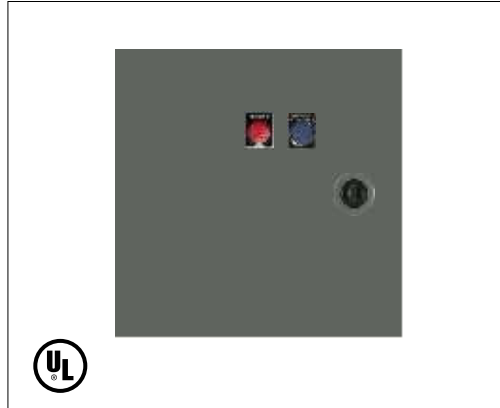

The Danfoss GFEP Contactor Panel is primarily designed for snow and ice melting applications. The integral 30mA Ground Fault Protection ensures safety along with NEC and local codes requirements. The panel can be activated by a Danfoss GX850 ACP, DS-2B, DS-5, DS-8 or other type of controller.

- Low cost
- Simple Installation
- NEMA 1, UL listed enclosure
- Integrated 30mA GFEP
- A LED trip indicator ( internal )
- A LED heat on indicator
- Pre-wired terminal connections
- 120V on/off remote heat indication

### Specifications

Max. lead voltage	600V
Max. heating load:	100A/200A
Control voltage:	120V
Enclosure type	NEMA 1
Mounting	Wall mounted, indoors
Dimensions: (HxWxD)	12"x 12" 6"
GFEP:	Integrated 30mA trip

Note: The system is not for use with applications requiring 5mA ground fault protection.  
Optional: four hour timer available

### Typical Wiring Diagram

Simplified single phase connected heating cables

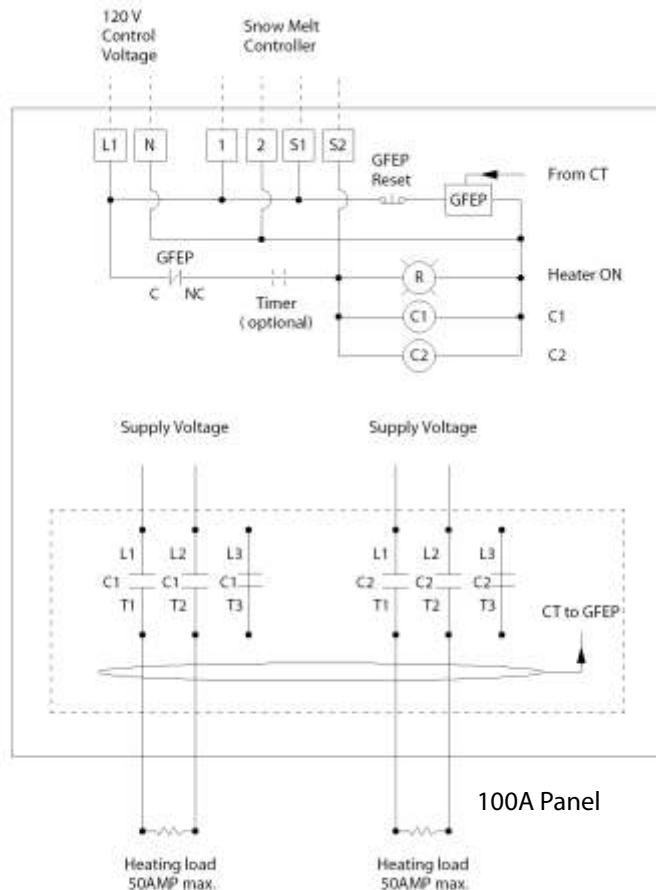

## Typical Wiring Diagram

Simplified three phase connected heating cables

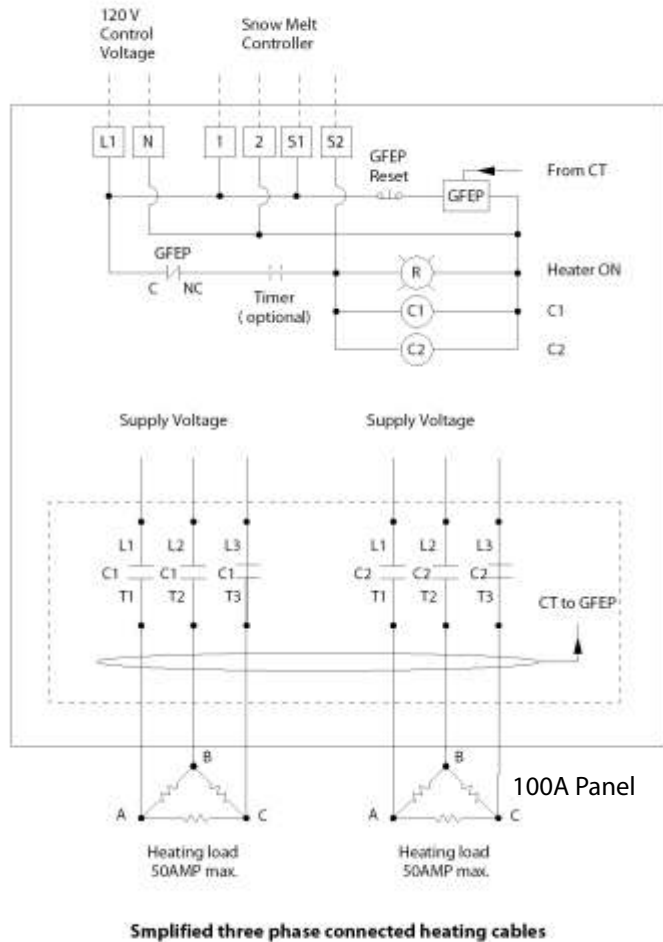

## Ordering Information

Part No.	Description
088L3444	GX Contactor Panel with timer and GFEP, 100A
088L3445	GX Contactor Panel with GFEP, 100A
088L3446	GX Contactor Panel with timer and GFEP, 200A
088L3447	GX Contactor Panel with GFEP, 200A

## Warranty

Two year comprehensive extended warranty against defects in material, design, and workmanship.

## Technical Services

For technical questions, please contact Danfoss Heating Division North America at 1- 866-676-8062, or via the web at [www.LX.Danfoss.com](http://www.LX.Danfoss.com)

Danfoss can accept no responsibility for possible errors in catalogues, brochures, other printed materials, and website information. Danfoss reserves the right to alter its products without notice. This also applies to products already on order provided that such alteration can be made without subsequent changes being necessary in specifications already agreed upon. All trademarks in this material are property of the respective companies. Danfoss and the Danfoss logotype are registered trademarks of Danfoss A/S. All rights reserved.



Danfoss Inc.  
 Toronto  
 Toll Free: 866-676-8062  
 Phone: 905-285-2050  
 Fax: 905-285-2055  
[www.LX.Danfoss.com](http://www.LX.Danfoss.com)

**Danfoss GX**  
 BRINGING WARMTH TO LIFE