

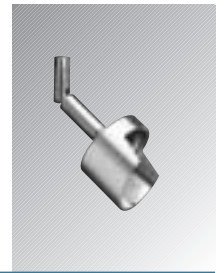

Litelab Corp. | Jewelers' Collection  
 251 Elm Street Buffalo, NY 14203 USA  
 1-800-238-4120, fax 716-856-0156, www.litelab.com

job name: \_\_\_\_\_

fixture type: \_\_\_\_\_



**Machined Rings Collection**  
**Incandescent | 12-Volt**

**Wall-Wash | Stem**

**AR-70**

**Lamp**



12-volt, Incandescent  
 AR-70  
 (by others)

**Base Fixture Models**

12-V.A.C.	LAMP TYPE	MAX. WATTAGE	ETL LISTED US
<b>J18AR70</b>	AR-70	50-watt	

**Features**

- Material(s):** 6000-series aluminum, precision-machined to blemish-free architectural finish.
- Lamp Ring:** machined to .187" seamless wall thickness; internally threaded to accept retaining ring for lamp and one or two accessories held level behind 90° front return.
- Socket Cup:** machined to .062" seamless wall thickness, securely fastened to ceramic socket; leads enclosed in swivel-joint stem permitting non-drifting 90° aiming angle and 360° rotation.
- Input:** 12 VAC
- Temperature:** 40° C. (104° F.) ambient maximum
- Weight:** approx. 0.9 lb. with lamp and BusRun fitting.

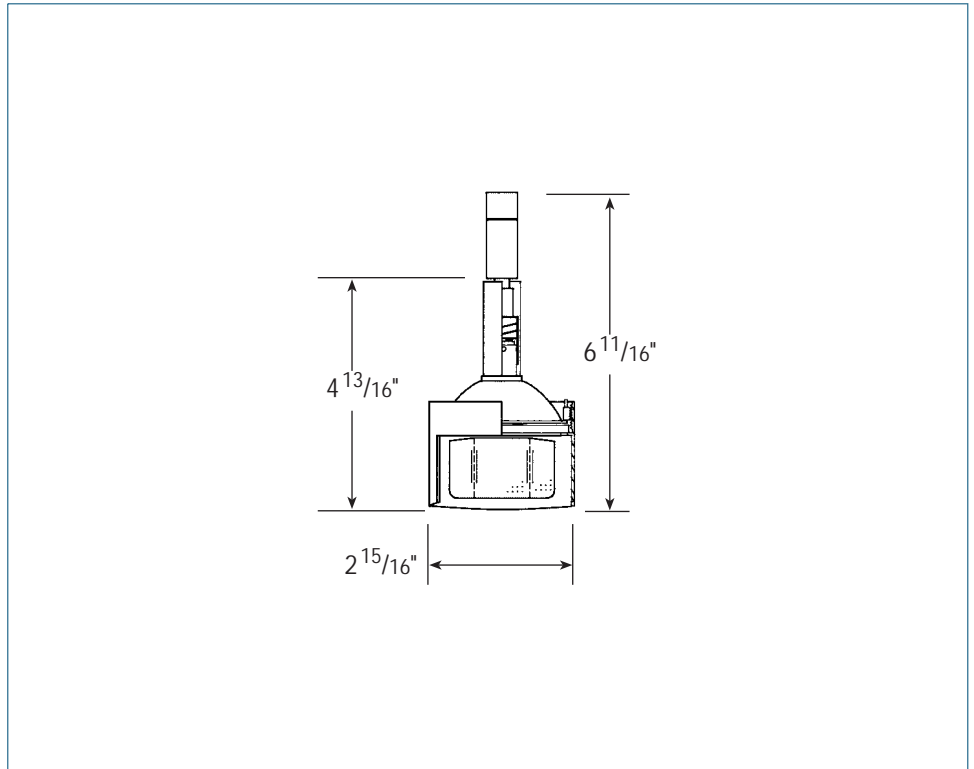

**Specify:**

DESCRIPTION:	BASE FIXTURE MODEL	FITTING	FINISH	ACCESSORIES (OPTIONAL)
example:	J18AR70	-9i	-NT	-OL-5X55-m

**Finishes**

NT	Natural Aluminum
MB	Black
P	White

**Accessories**

- GLASS FILTERS
  - OL-5X55-m 5' x 55" linear spread lens
  - OL-SOLITE-m Beam Softener
  - OL-FLAT-m-UV Bausch & Lomb® Optivex™ UV filter
  - LOUVERS & SCREENS
  - LVH/m hex cell louver
  - B-15/m 15% light-blocking screen
- consult for color glass

**Fittings**

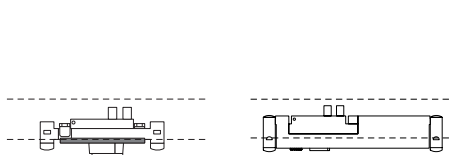

**BusRun® Busway**  
**9B** fused plug-in fitter for use with 12V BusRun busway

**BusRun® Busway**  
**9i** fused plug-in fitter with integral transformer for use with 120V BusRun busway

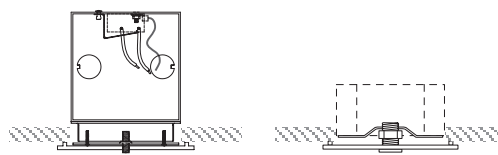

**Machined Canopy**  
**3E** machined canopy and 4" x 4" x 4" junction box with electronic low-voltage power supply.

**Machined Canopy**  
**3** machined canopy and mounting bracket for 4" octagon box by others and remote transformer (ordered separately).