

Hi-lume 3D Overview

Hi-lume 3D architectural electronic dimming ballasts are designed to meet the most demanding lighting requirements. By providing industry leading performance with a full-range of 100% to less than 1% fluorescent dimming, Hi-lume 3D ballasts enable you to provide the ideal visual environment for any application.

Features

- Continuous, flicker-free dimming from 100% to 0.7% for T8, 1% for T5 and T5HO, and 5% for T5 twin-tube
- Supports standard 3-wire line-voltage phase-control technology for consistent fixture-to-fixture dimming performance
- Compatible with EcoSystem® Energi Savr Node™, GRAFIK Eye® QS with EcoSystem, and Quantum® systems, allowing for integration into an existing/planned EcoSystem lighting control system
- Programmed rapid start design preheats lamp cathodes before applying full arc voltage to ensure full-rated lamp life while dimming and cycling
- Lamps turn on to any dimmed level without flashing to full brightness
- Low harmonic distortion throughout the entire dimming range maintains power quality
- Frequency of operation ensures that ballast does not interfere with infrared devices operating between 38 kHz and 42 kHz
- Inrush current limiting circuitry eliminates circuit breaker tripping, switch arcing, and relay failure
- Ballasts maintain consistent light output for different lamp lengths, ensuring fixture-to-fixture uniformity
- Ultra-quiet operation
- Protected from miswires of any input power to control lead, or from lamp leads to each other and/or ground
- 100% compatible with all Lutron 3-wire fluorescent controls and EcoSystem digital controls
- 100% performance tested at factory
- 5-year limited warranty with Lutron field service commissioning (3-year standard warranty) from date of purchase



Hi-lume 3D, case type C

1.18 in W (30 mm) x 1.00 in H (25 mm) x 18.00 in L (457 mm)



Hi-lume 3D, case type G

2.38 in W (60 mm) x 1.00 in H (25 mm) x 9.50 in L (241 mm)

Job Name:

Model Numbers:

Job Number:

Specifications

Performance

- Dimming Range: 100% to 0.7% measured relative light output (RLO) for T8, 100% to 1% measured RLO for T5 and T5HO, and 100% to 5% measured RLO for T5 twin-tube.
- Lamp Starting: programmed rapid start
- Relative Humidity: maximum 90% noncondensing
- Lamp Current Crest Factor: less than 1.7
- Lamp Flicker: none visible
- Light Output Variation: constant $\pm 2\%$ light output for line voltage variations of $\pm 10\%$
- Lamp Life: average lamp life meets or exceeds rating of lamp manufacturer
- Power Factor: greater than 0.95
- Total Harmonic Distortion (THD): less than 10%
- Maximum Inrush Current: 7 amps per ballast at 120 V, 3 amps per ballast at 277 V
- Operating Voltage: Universal input 120 V, 220/240 V, 277 V, 50/60 Hz
- Frequency of Operation: greater than 42 KHz
- Ballast Factor: 1.0/1.17 for T8 lamps and 1.0 for T5, T5HO, and T5 twin-tube lamps

Dimming Range for T5 and T5HO lamps:

BF	Dimming Range (Max/Min (BF))	Dimming Ratio
1.0	1.00 / 0.01	100:1

Dimming Range for T8 lamps:

BF	Dimming Range (Max/Min (BF))	Dimming Ratio
1.17	1.17 / 0.0085	138:1
1.0	1.00 / 0.0085	118:1

Dimming Range for T5 Twin Tube lamps:

BF	Dimming Range (Max/Min (BF))	Dimming Ratio
1.0	1.00 / 0.05	100:5

Environment

- Minimum lamp starting temperature: 50 °F (10 °C)
- Relative humidity: less than 90% non-condensing
- Sound Rating: inaudible in a 27 dB ambient
- Maximum ballast case temperature: 167 °F (75 °C)

Standards

- California Energy Commission Listed
- UL Listed (evaluated to the requirements of UL935)
- CSA certified (evaluated to the requirements of C22.2 No. 74) (specific model numbers only)
- Class P thermally protected
- Meets ANSI C82.11 High Frequency Ballast Standard
- Meets FCC Part 18 Non-Consumer requirements for EMI/RFI emissions
- Meets ANSI C62.41 Category A surge protection standards up to and including 6 kV
- Manufacturing facilities employ ESD reduction practices that comply with the requirements of ANSI/ESD S20.20
- Lutron Quality Systems registered to ISO 9001.2000

Ballast Wiring & Mounting

- Ballast is grounded via a mounting screw to the fixture
- Ballast mounts using two screws (or sheet metal feature and one screw) within a fluorescent fixture.
- Power and lamp wiring terminals accept only one 18 AWG (1.0 mm²) solid wire per terminal

Lamp Seasoning

Refer to the lamp manufacturer's requirements for lamp seasoning requirements prior to dimming.

Job Name:	Model Numbers:
Job Number:	

Hi-lume 3D Ballasts for Linear and U-Bent T8 Lamps

Lamp Type	Lamp Watts (length)	Lamps per Ballast	Case Size	Hi-lume 3D	Input Voltage (VAC)	Ballast Current (A)	Ballast Factor (BF)	Input Power (W)	System Lumens* (lm)	System Efficacy* (lm/W)	Ballast Efficacy Factor (BEF)	Relative System Efficacy (RSE)
	40W (60 in)	1	C	H3D T840 C U 1 10	277	0.16	1.00	42.8	3800	89	2.34	0.94
					240	0.18	1.00	43.0	3800	88	2.33	0.93
					120	0.37	1.00	43.8	3800	87	2.28	0.91
		1	C	H3D T840 C U 1 17	277	0.18	1.17	49.6	4446	90	2.36	0.94
	240				0.21	1.17	49.4	4446	90	2.37	0.95	
	2	C	H3D T840 C U 2 10	277	0.32	1.00	88.9	7600	86	1.13	0.90	
				240	0.37	1.00	88.4	7600	86	1.13	0.91	
	2	C	H3D T840 C U 2 17	277	0.36	1.17	98.2	8892	91	1.19	0.95	
				240	0.41	1.17	97.2	8892	92	1.20	0.96	
	2	C	H3D T840 C U 2 17	120	0.84	1.17	100.3	8892	89	1.17	0.93	
	32 W (48 in)	1	C	H3D T832 C U 1 10	277	0.13	1.00	34.8	3000	86	2.87	0.92
					240	0.15	1.00	35.0	3000	86	2.85	0.91
		1	G	H3D T832 G U 1 10	120	0.30	1.00	35.1	3000	85	2.85	0.91
		1	C	H3D T832 C U 1 17	277	0.15	1.17	39.7	3510	88	2.95	0.94
					240	0.17	1.17	40.0	3510	88	2.92	0.94
		1	G	H3D T832 G U 1 17	120	0.34	1.17	40.1	3510	88	2.92	0.93
		2	C	H3D T832 C U 2 10	277	0.24	1.00	65.7	6000	91	1.52	0.97
					240	0.28	1.00	66.3	6000	90	1.51	0.97
		2	G	H3D T832 G U 2 10	120	0.58	1.00	66.5	6000	90	1.50	0.96
		2	C	H3D T832 C U 2 17	277	0.28	1.17	75.4	7020	93	1.55	0.99
240					0.31	1.17	76.5	7020	92	1.53	0.98	
2		G	H3D T832 G U 2 17	120	0.67	1.17	76.9	7020	91	1.52	0.97	
3	G	H3D T832 G U 3 10	277	0.37	1.00	93.5	9000	96	1.07	1.03		
			240	0.40	1.00	94.9	9000	96	1.05	1.01		
3	G	H3D T832 G U 3 10	120	0.83	1.00	95.4	9000	96	1.05	1.01		
3	G	H3D T832 G U 3 17	277	0.41	1.17	105.7	10,530	100	1.11	1.06		
			240	0.47	1.17	106.5	10,530	99	1.10	1.05		
3	G	H3D T832 G U 3 17	120	0.95	1.17	106.8	10,530	99	1.10	1.05		
25 W (36 in)	1	C	H3D T825 C U 1 10	277	0.11	1.00	29.1	1900	65	3.44	0.86	
				240	0.12	1.00	28.9	1900	66	3.46	0.87	
				120	0.25	1.00	29.9	1900	64	3.34	0.84	
	1	C	H3D T825 C U 1 17	277	0.12	1.17	33.5	2223	66	3.49	0.87	
				240	0.14	1.17	33.1	2223	67	3.53	0.88	
				120	0.29	1.17	33.8	2223	66	3.46	0.87	
	2	C	H3D T825 C U 2 10	277	0.22	1.00	56.0	3800	68	1.79	0.89	
				240	0.24	1.00	56.0	3800	68	1.79	0.89	
2	C	H3D T825 C U 2 17	120	0.49	1.00	59.0	3800	64	1.69	0.85		
2	C	H3D T825 C U 2 17	277	0.24	1.17	62.3	4446	71	1.88	0.94		
			240	0.27	1.17	61.8	4446	72	1.89	0.95		
2	C	H3D T825 C U 2 17	120	0.55	1.17	64.0	4446	69	1.83	0.91		

* Actual number may vary with lamp model. Please consult lamp manufacturer for lamp-specific data.

Job Name:	Model Numbers:
Job Number:	

Hi-lume 3D Ballasts for Linear and U-Bent T8 Lamps (continued)

Lamp Type	Lamp Watts (length)	Lamps per Ballast	Case Size	Hi-lume 3D	Input Voltage (VAC)	Ballast Current (A)	Ballast Factor (BF)	Input Power (W)	System Lumens* (lm)	System Efficacy* (lm/W)	Ballast Efficacy Factor (BEF)	Relative System Efficacy (RSE)
	17 W (24 in)	1	C	H3D T817 C U 1 10	277	0.08	1.00	22.9	1300	57	4.37	0.74
			G	H3D T817 G U 1 10	240	0.09	1.00	22.6	1300	58	4.42	0.75
		1	C	H3D T817 C U 1 17	277	0.09	1.17	25.3	1521	60	4.62	0.79
			G	H3D T817 G U 1 17	240	0.10	1.17	25.3	1521	60	4.62	0.79
		2	C	H3D T817 C U 2 10	277	0.14	1.00	38.7	2600	67	2.58	0.88
			G	H3D T817 G U 2 10	240	0.16	1.00	38.4	2600	68	2.60	0.89
	2	C	H3D T817 C U 2 17	277	0.15	1.17	41.8	3042	73	2.80	0.95	
		G	H3D T817 G U 2 17	240	0.18	1.17	41.7	3042	73	2.81	0.95	
	3	G	3	H3D T817 G U 3 10	277	0.21	1.00	57.2	3900	68	1.75	0.89
					240	0.25	1.00	56.9	3900	69	1.76	0.90
	3	G	3	H3D T817 G U 3 17	120	0.48	1.00	57.5	3900	68	1.74	0.89
					277	0.23	1.17	64.4	4563	71	1.75	0.93
3	G	3	H3D T817 G U 3 17	240	0.27	1.17	64.9	4563	70	1.76	0.92	
				120	0.55	1.17	65.6	4563	70	1.74	0.91	

Hi-lume 3D Ballasts for Linear T5 Lamps

Lamp Type	Lamp Watts (length)	Lamps per Ballast	Case Size	Hi-lume 3D	Input Voltage (VAC)	Ballast Current (A)	Ballast Factor (BF)	Input Power (W)	System Lumens* (lm)	System Efficacy* (lm/W)	Ballast Efficacy Factor (BEF)	Relative System Efficacy (RSE)
	28 W (45.2 in)	1	C	H3D T528 C UNV 1 10	277	0.12	1.00	32.1	2900	89	3.07	0.86
					240	0.13	1.00	32.2	2900	88	3.04	0.85
					120	0.27	1.00	32.5	2900	88	3.04	0.85
		2	C	H3D T528 C UNV 2 10	277	0.23	1.00	64.1	5800	90	1.55	0.87
					240	0.26	1.00	64.0	5800	89	1.54	0.86
					120	0.54	1.00	65.0	5800	89	1.53	0.86
	21 W (33.4 in)	1	C	H3D T521 C UNV 1 10	277	0.09	1.00	25.2	2100	83	3.97	0.83
					240	0.10	1.00	24.9	2100	84	4.02	0.84
2		C	H3D T521 C UNV 2 10	120	0.22	1.00	25.8	2100	81	3.88	0.81	
				277	0.18	1.00	48.6	4200	86	2.06	0.86	
2	C	H3D T521 C UNV 2 10	240	0.20	1.00	47.9	4200	88	2.09	0.88		
			120	0.41	1.00	49.2	4200	85	2.03	0.85		
14 W (21.6 in)	1	C	H3D T514 C UNV 1 10	277	0.07	1.00	19.1	1350	71	5.24	0.73	
				240	0.08	1.00	18.5	1350	73	5.41	0.76	
				120	0.16	1.00	18.8	1350	72	5.32	0.74	
	2	C	H3D T514 C UNV 2 10	277	0.13	1.00	35.4	2700	76	2.82	0.79	
				240	0.15	1.00	35.2	2700	77	2.84	0.80	
				120	0.29	1.00	35.3	2700	76	2.83	0.79	

* Actual number may vary with lamp model. Please consult lamp manufacturer for lamp-specific data.

Job Name:	Model Numbers:
Job Number:	

Hi-lume 3D Ballasts for Linear T5HO Lamps

Lamp Type	Lamp Watts (length)	Lamps per Ballast	Case Size	Hi-lume 3D	Input Voltage (VAC)	Ballast Current (A)	Ballast Factor (BF)	Input Power (W)	System Lumens* (lm)	System Efficacy* (lm/W)	Ballast Efficacy Factor (BEF)	Relative System Efficacy (RSE)
T5HO	54 W (42.5 in)	1	C	H3D T554 C U 1 10	277	0.20	1.00	55.7	5000	90	1.80	1.44
					240	0.27	1.00	64.6	5000	77	1.55	0.62
					120	0.51	1.00	60.8	5000	82	1.64	0.66
	39 W (33.4 in)	1	C	H3D T539 C U 1 10	277	0.16	1.00	43.6	3500	80	2.29	1.83
					240	0.18	1.00	43.5	3500	80	2.30	1.84
					120	0.38	1.00	44.7	3500	78	2.24	1.79
24 W (21.6 in)	1	C	H3D T524 C U 1 10	277	0.11	1.00	29.1	2000	69	3.44	2.75	
				240	0.12	1.00	28.0	2000	71	3.57	2.85	
				120	0.24	1.00	28.7	2000	70	3.48	2.78	
	2	C	H3D T524 C U 2 10	277	0.19	1.00	51.0	4000	78	1.96	0.78	
				240	0.22	1.00	51.6	4000	78	1.94	1.55	
				120	0.44	1.00	51.9	4000	77	1.93	1.54	

Hi-lume 3D Ballasts for Twin-Tube T5 Lamps

Lamp Type	Lamp Watts (length)	Lamps per Ballast	Case Size	Hi-lume 3D	Input Voltage (VAC)	Ballast Current (A)	Ballast Factor (BF)	Input Power (W)	System Lumens* (lm)	System Efficacy* (lm/W)	Ballast Efficacy Factor (BEF)	Relative System Efficacy (RSE)
T5 Twin-Tube	50 W (22.5 in)	1	G	H3D T550 G U 1 10	277	0.20	1.00	54.8	4000	73	1.82	0.73
					240	0.23	1.00	54.6	4000	73	1.83	0.73
					120	0.45	1.00	53.5	4000	75	1.87	0.75
		2	G	H3D T550 G U 2 10	277	0.36	1.00	98.7	8000	81	1.01	0.81
					240	0.42	1.00	99.8	8000	80	1.00	0.40
					120	0.84	1.00	99.8	8000	80	1.00	0.40
	40 W (22.5 in)	1	G	H3D T540 G U 1 10	277	0.16	1.00	43.9	3100	71	2.28	0.91
					240	0.18	1.00	42.8	3100	72	2.34	1.87
					120	0.36	1.00	42.8	3100	72	2.34	1.87
		2	G	H3D T540 G U 2 10	277	0.27	1.00	74.0	6200	84	1.35	1.08
					240	0.32	1.00	76.0	6200	82	1.32	1.05
					120	0.64	1.00	76.0	6200	82	1.32	1.05
3	G	H3D T540 G U 3 10	277	0.40	1.00	109.7	9300	85	0.91	1.09		
			240	0.47	1.00	111.7	9300	83	0.90	0.72		
			120	0.95	1.00	112.9	9300	82	0.89	0.71		
36 W (15.5 in)	1	G	H3D T536 G U 1 10	277	0.14	1.00	38.4	2850	74	2.60	1.04	
				240	0.17	1.00	40.4	2850	71	2.48	1.98	
	2	G	H3D T536 G U 2 10	277	0.26	1.00	71.3	5700	80	1.40	1.12	
				240	0.31	1.00	73.7	5700	77	1.36	1.09	
				120	0.61	1.00	72.5	5700	79	1.38	1.10	

Job Name:	Model Numbers:
Job Number:	

Case Dimensions

C

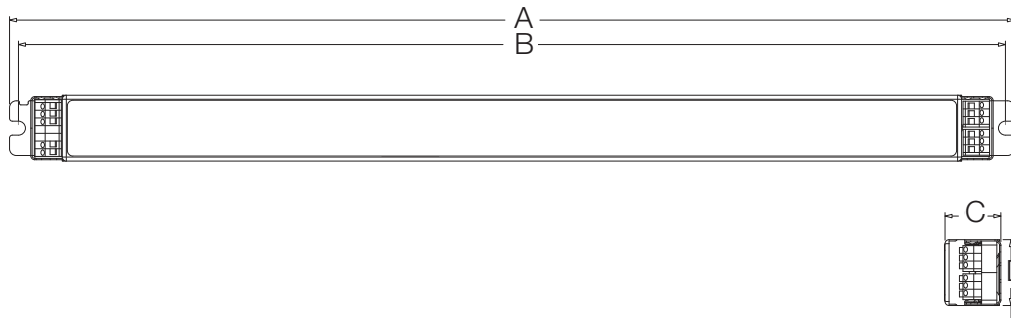

- A 18.00 in (457 mm)
- B 17.68 in (449 mm)
(mounting centers)
- C 1.0 in (25 mm)
- D 1.18 in (30 mm)

G

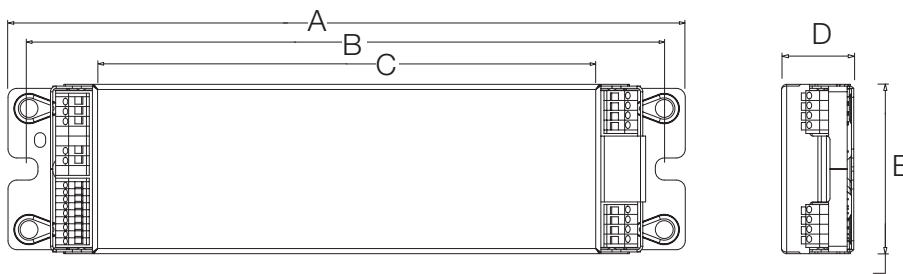

- A 9.5 in (241 mm)
- B 8.9 in (226 mm)
(mounting centers)
- C 7.1 in (180 mm)
- D 1.0 in (25 mm)
- E 2.38 in (60 mm)

Job Name:	Model Numbers:
Job Number:	

Hi-lume 3D Dimmer Wiring

3-Wire Control Wiring



WARNING: Shock hazard. May result in serious injury or death. Disconnect power before servicing or installing.

- Make sure that the supply breaker to the Digital Ballast is OFF when wiring
- Wire as shown

Line input:	Connects to:
Hot	Dimmer Black Wire
Neutral	Dimmer White Wire

Dimmer wire:	Connects to:
Yellow	Ballast Orange (DH)
Red	Ballast Black (HOT)
White	Ballast White (NEU)
Green	Earth Ground

- Hi-lume 3D ballast line voltage and 3-wire input terminals only accept one 18 AWG (1.0 mm²) solid wire

Emergency and 3-wire

- Ballasts controlled by a wallbox dimmer should not be used for emergency/egress lighting unless an external emergency ballast is used in the fixture. See *Lutron App. Note #50*.
- Ballasts may be used for emergency/egress lighting when controlled by a *Lutron* dimming panel (GP) and the panel is a dedicated emergency panel.

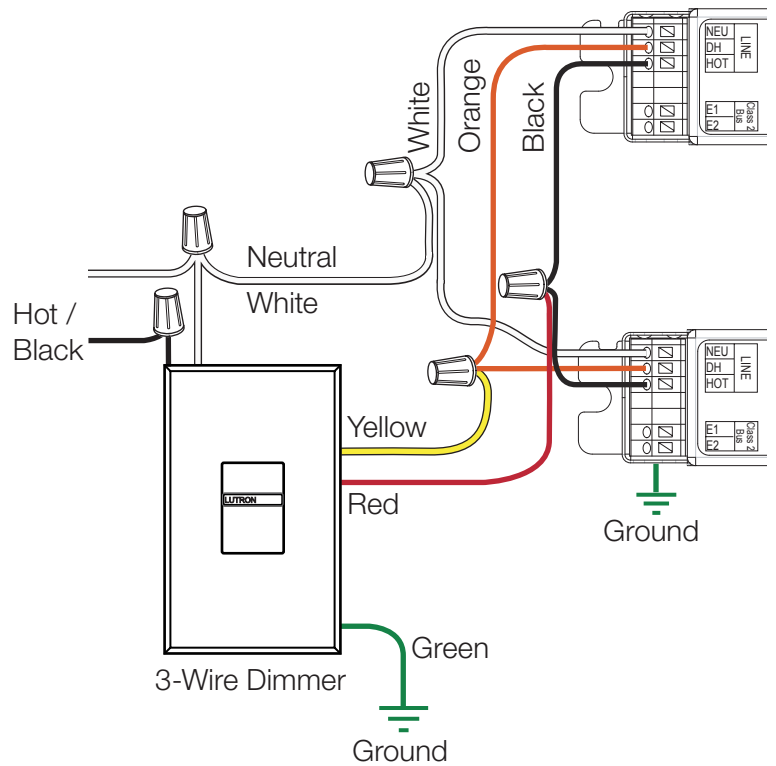

Job Name:	Model Numbers:
Job Number:	

Hi-lume 3D Wiring Diagrams

EcoSystem® Bus Overview

- The *EcoSystem* Bus wiring (E1 and E2) connects the digital ballasts together to form a lighting control system
- Each *EcoSystem* Bus supports up to 64 digital ballasts, 32 occupant sensors, 16 daylight sensors, and 64 wallstations or IR receivers
- Sensors do not directly connect to *Hi-lume* 3D ballasts
- E1 and E2 (*EcoSystem* bus wires) are polarity insensitive and can be wired in any topology
- An *EcoSystem* Bus Supply provides power for the *EcoSystem* Bus and supports system programming
- All *EcoSystem* Bus programming is completed by using the *EcoSystem* Programmer, GRAFIK Eye® QS with *EcoSystem*, or Quantum®

EcoSystem Bus Wiring

- Ballast *EcoSystem* Bus terminals only accept one 18 AWG (1.0 mm²) solid wire
- Make sure that the supply breaker to the Digital Ballast and *EcoSystem* Bus Supply is OFF when wiring
- Connect the two conductors to the two Digital Ballast terminals E1 and E2 as shown
- Using two different colors for E1 and E2 will reduce confusion when wiring several ballasts together
- The *EcoSystem* bus may be wired Class 1 or Class 2. Consult applicable electrical codes for proper wiring practices

Notes

- The *EcoSystem* Bus Supply does not have to be located at the end of the Digital Loop
- *EcoSystem* Bus length is limited by the wire gauge used for E1 and E2 as follows:

Wire Gauge	Bus Length (max)
12 AWG (4.0 mm ²)	2200 ft (670 m)
14 AWG (2.5 mm ²)	1400 ft (427 m)
16 AWG (1.5 mm ²)	900 ft (274 m)

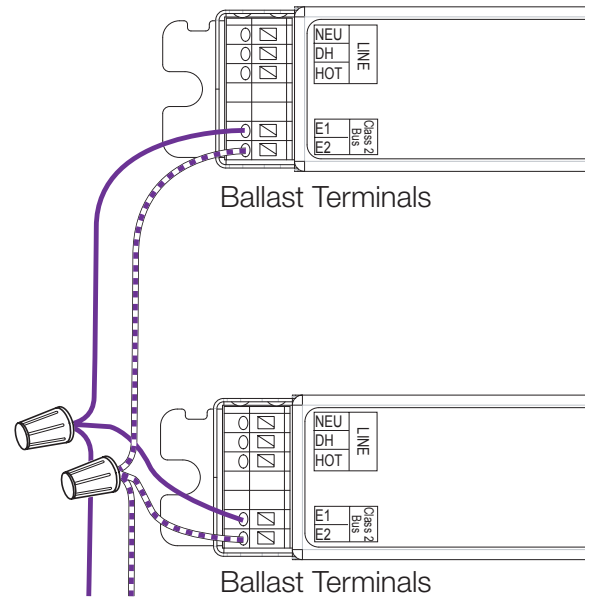

To the *EcoSystem* Bus Supply & up to 64 total ballasts

Job Name:	Model Numbers:
Job Number:	

Hi-lume 3D Ballast Wiring Diagrams – T8, T5, and T5HO linear lamps

Wiring to One Lamp (C case shown)

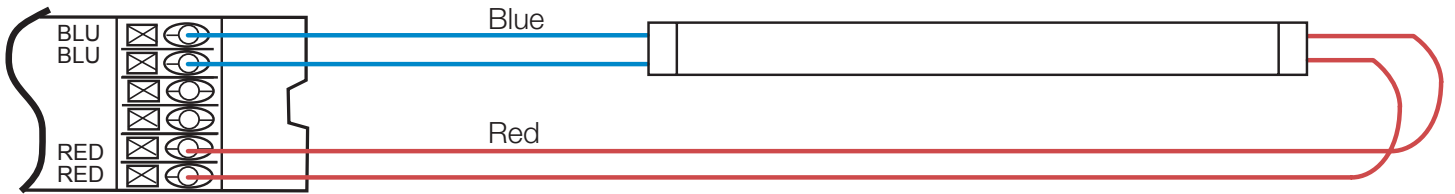

Wiring to Two Lamps (C case shown)

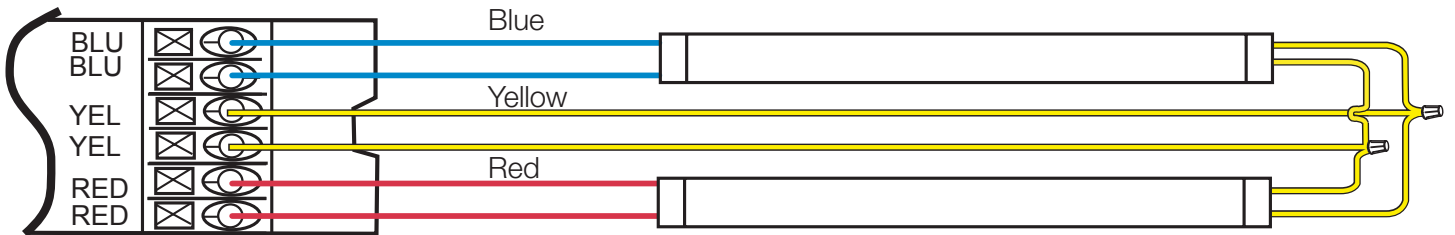

NOTICE

- Maximum ballast to lamp socket lead length is 7 ft (2 m)
- Wire colors shown are labeled on the ballast, but may vary depending upon fixture construction

Job Name:	Model Numbers:
Job Number:	

Hi-lume 3D Ballast Wiring Diagrams – T8, T5, and T5HO linear lamps

Wiring to One Lamp (G case shown)

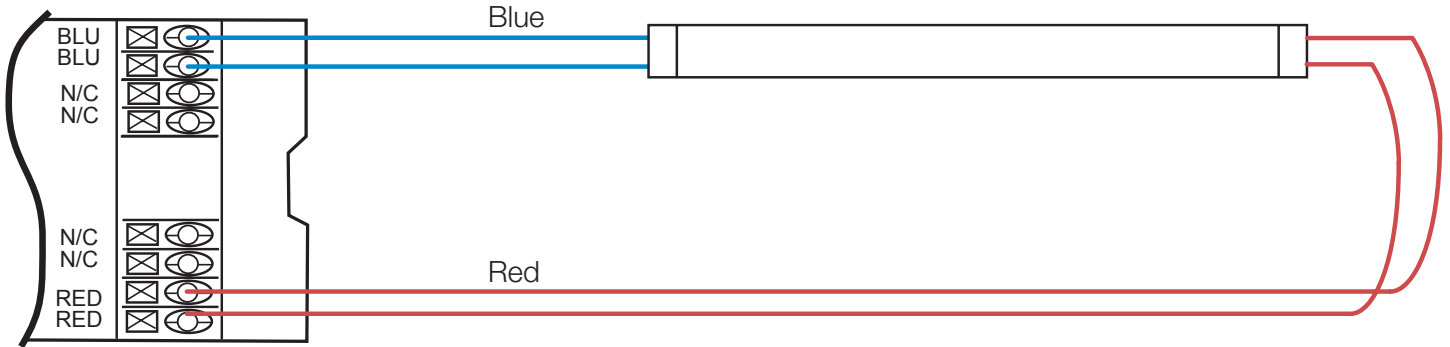

Wiring to Two Lamps (G case shown)

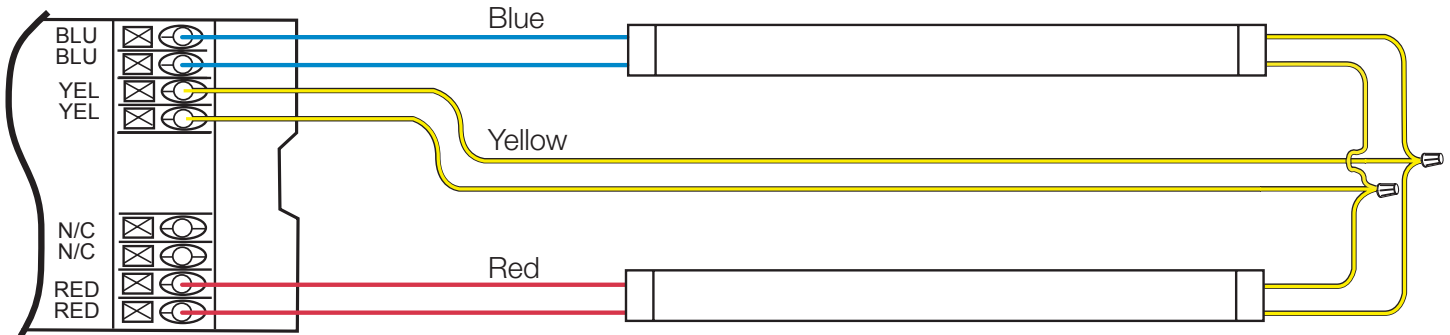

Wiring to Three Lamps (G case shown)

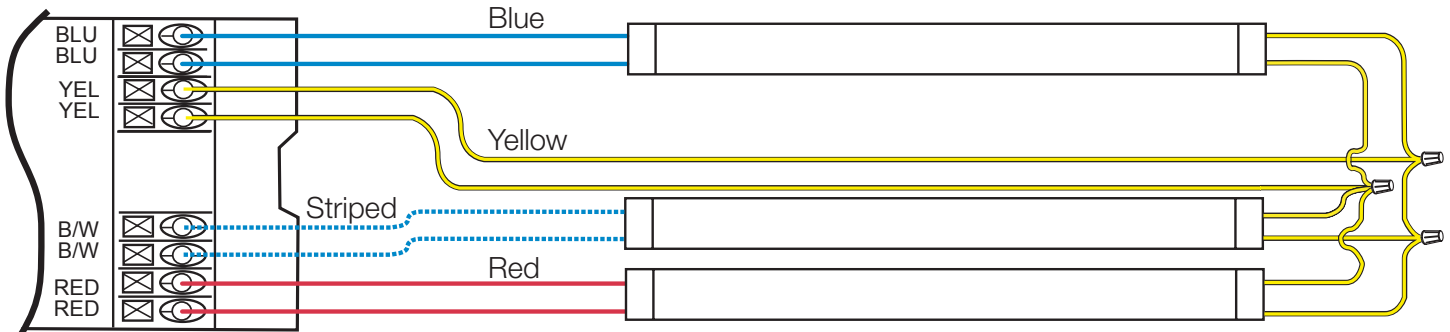

NOTICE

- Maximum ballast to lamp socket lead length is 7 ft (2 m)
- Wire colors shown are labeled on the ballast, but may vary depending upon fixture construction

Job Name:	Model Numbers:
Job Number:	

EcoSystem Ballast Wiring Diagrams - T5 Twin-Tube

Wiring to One Lamp

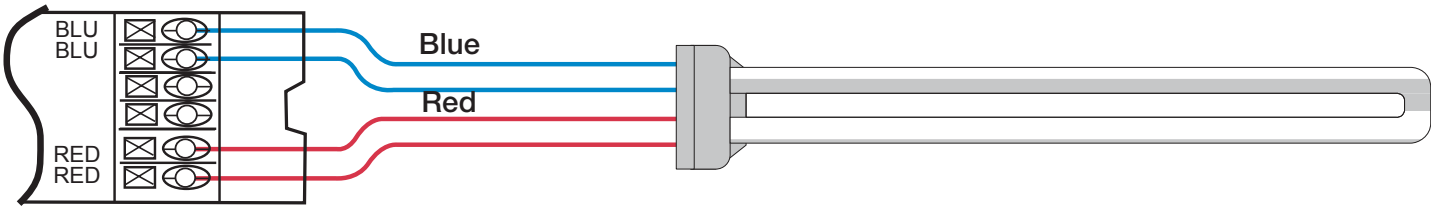

Wiring to Two Lamps

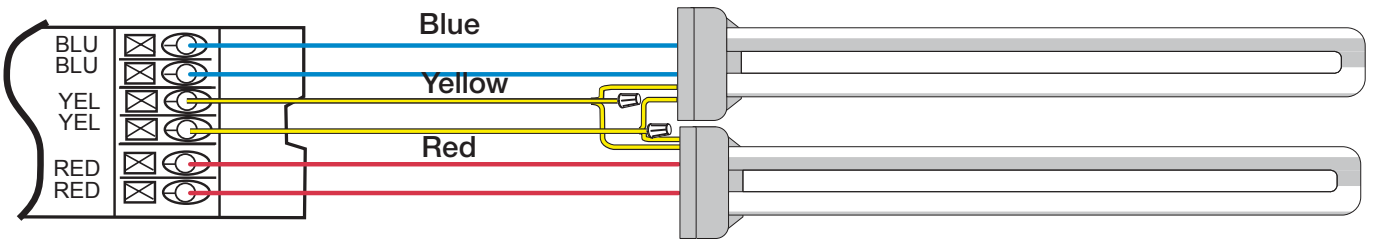

Wiring to Three Lamps

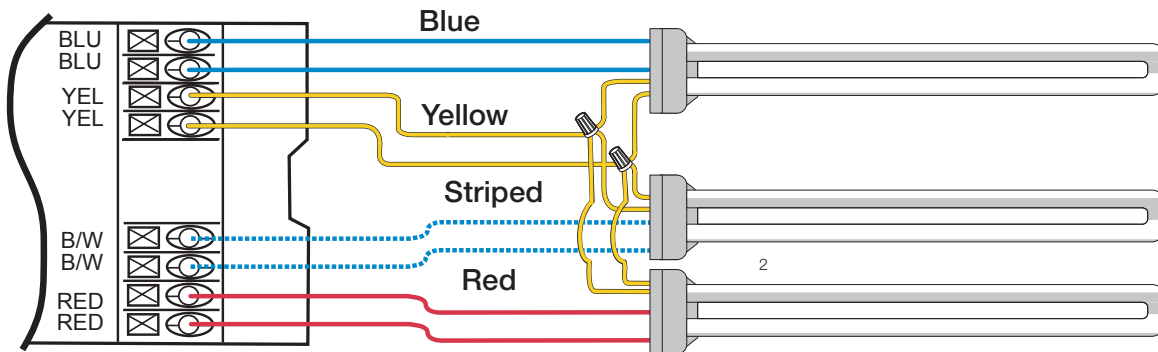

NOTICE

- Maximum ballast to lamp socket lead length is 3 feet (1 m)
- Wire colors shown are labeled on the ballast, but may vary depending upon fixture construction

Job Name:	Model Numbers:
Job Number:	

ATTENTION ELECTRICIANS AND CONTRACTORS

Ballast/Socket Leads

Lead lengths from ballast to socket must not exceed 7 ft (2 m) for linear lamps (T5, T5HO, T8). Lead lengths must not exceed 3 feet (1 m) for T5 twin tube lamps.

Lamp Sockets

Lamp sockets as per IEC 60400 are required to ensure positive lamp-pin to socket contact.

Lamp Mounting

Many fluorescent lamp sockets are available with mounting slots to vary the height of the lamp away from the grounded metal surface. Use these slots to get the lamp glass to be 1/2 in ± 1/4 in away from the grounded metal surface for T8 lamps and 3/8 in ± 1/8 in for T5 lamps.

Having a fluorescent lamp too close to the grounded metal will make the minimum intensity too low and will reduce lamp life. Having a fluorescent lamp too far away from the grounded metal will make the lamp flicker or not turn on at all.

Ballast Operating Temperature

Ballast case temperature must not exceed 167 °F (75 °C) at any point on ballast.

Wiring and Grounding

Ballast and lighting fixture must be effectively grounded. Ballasts must be installed per national and local electrical codes.

ATTENTION FACILITIES MANAGERS

PERFORMANCE

Lamp Seasoning

Consult lamp manufacturer's recommendations on lamp seasoning prior to dimming.

SERVICE

Replacement Parts

Use replacement parts with exact Lutron model numbers. Consult Lutron if you have any questions.

Further Information

For further information, please visit us at www.lutron.com/ballasts or contact our 24-hour Technical Support Center at 1-800-523-9466.

Job Name:	Model Numbers:
Job Number:	