

QS Sensor Module

The QS Sensor Module (QSM) is a ceiling-mounted device that integrates Lutron® wireless and wired sensors and controls through the QS communication link to Energi Savr Node™ (ESN) units, GRAFIK Eye® QS control units, Quantum® systems, Sivoia® QS shades/draperies, and myRoom™ control modules.



Features

- Uses Clear Connect® RF Technology for communication with Radio Powr Savr™ occupancy sensors, Radio Powr Savr™ daylight sensors, and Pico® wireless controllers.
- QSM connects to four Lutron® wired sensors or controls—occupancy sensors, daylight sensors, EcoSystem® infrared (IR) receivers, or EcoSystem® wallstations. Does not apply to wireless only models.
- Powered by the QS link—no line voltage connections are required.
- Contact Lutron for compatibility details with the Quantum® system.
- Compatible with the entire ESN product family:
 - Allows Lutron® wired occupancy sensors, daylight sensors, EcoSystem® wall stations, EcoSystem® IR receivers, Pico® wireless controllers, Radio Powr Savr™ wireless occupancy sensors and daylight sensors to control ESN units.
- Compatible with GRAFIK Eye® QS control units.
 - GRAFIK Eye® QS control unit models starting with QSGR.
- Allows Lutron® wired or Radio Powr Savr™ wireless occupancy sensors and daylight sensors linked to a QSM to control the GRAFIK Eye® QS control unit.
- Contact Lutron for compatibility with Pico® wireless controllers, EcoSystem® wallstations, and EcoSystem® infrared (IR) receivers.
- Compatible with Sivoia® QS shades/ draperies.
 - Allows Pico® wireless controllers to control Sivoia® QS shades/ draperies (QSM models with wireless inputs only).
- Compatible with myRoom™ power modules.
 - Allows Lutron wired & wireless occupancy sensors to control power modules.
 - Allows Pico® wireless controls to control power modules.

System Example

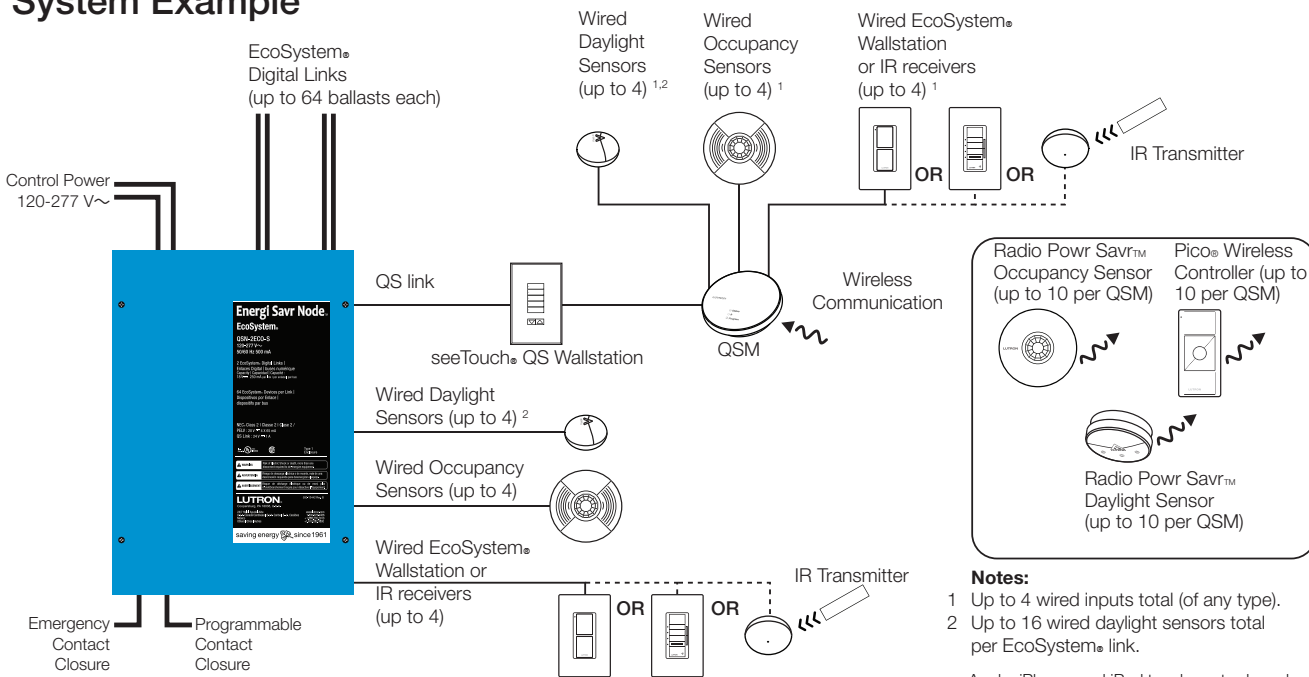

- Notes:**
- 1 Up to 4 wired inputs total (of any type).
 - 2 Up to 16 wired daylight sensors total per EcoSystem® link.

Apple, iPhone, and iPod touch are trademarks of Apple Inc., registered in the U.S. and other countries.

<p>Job Name:</p>	<p>Model Numbers:</p>
<p>Job Number:</p>	

Models

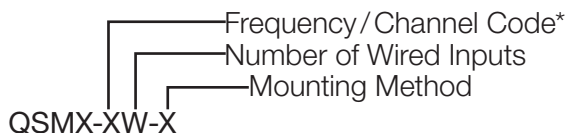

Frequency/Channel Code*

2—431.5 - 436.6 MHz	U.S.A., Canada and Mexico
3—868.1 - 869.8 MHz	European Union and United Arab Emirates
4—868.1 - 868.5 MHz	Singapore and China
5—865.5 - 866.5 MHz	India
7—433.0 - 434.7 MHz	Hong Kong
X—No RF	

*Contact Lutron for frequency/channel code compatibility with your particular geographic region if it is not indicated above.

Number of Wired Inputs

- 4—4
- X—None

Mounting Method

- C—Ceiling Mount
- J—Junction Box Ceiling Mount

Availability/Compatibility

Refer to the chart below to determine QSM model availability and compatibility with different sensor models.

Lutron® Radio Powr Savr™			
Models Available	Occupancy/Vacancy Sensors	Daylight Sensors *	Lutron® Pico® Wireless Controllers
QSM2-4W-C QSM2-XW-C QSM2-4W-J QSM2-XW-J	LRF2-OCRB-P, LRF2-OHLB-P, LRF2-OKLB-P, LRF2-OWLB-P, LRF2-VHLB-P, LRF2-VKLB-P, LRF2-VWLB-P, LRF2-OCR2B-WH, LRF2-VCR2B-WH	LRF2-DCRB	MRF2-3BRL, MRF2-3B, MRF2-2BRL, MRF2-2B, QSR4P-3R, PJ-2B-Gxx-xxx, PJ-2BRL-Gxx-xxx PJ-3B-Gxx-xxx PJ-3BRL-Gx-xxx
QSM3-4W-C QSM3-XW-C	LRF3-OCRB-P	LRF3-DCRB	QSRKP-2, QSRKP-2R, QSRKP-3R
QSM4-4W-C QSM4-XW-C	LRF4-OCRB-P	LRF4-DCRB	QSRMP-2, QSRMP-2R, QSRMP-3R
QSM5-XW-C	LRF5-OCRB-P	LRF5-DCRB	QSRNP-2, QSRNP-2R, QSRNP-3, QSRNP-3R
QSM7-4W-C QSM7-XW-C	LRF7-OCR2B-P	LRF7-DCRB	QSRQP-2, QSRQP-2R QSRQP-3, QSRQP-3R
QSMX-4W-C	N/A	N/A	N/A

* Daylight sensors can't be used as part of myRoom™ solutions.

Job Name:	Model Numbers:
Job Number:	

Specifications

QS Sensor Module (QSM)

Power

- 24–36 V_{DC}
- Current draw:
max 400 mA (models with wired input)
max 100 mA (models without wired input)
- Power Draw Units: (PDU)
Refer to the QS Link Power Draw Units specification submittal (Lutron® P/N 369405) for information concerning PDUs on the QS Link. Use only Lutron® approved power sources.
- 10-year power failure memory: restores settings and programming after power interruption.

Regulatory

- Lutron® Quality Systems registered to ISO 9001.2008.

QSM2 –

- cUL US Listed (USA and Canada).
- FCC Compliant. Complies with the limits for a Class B digital device, pursuant to Part 15 of the FCC Rules (USA).
- IC Certified. (Canada).
- SCT Certified (Mexico).

QSM3 –

- CE Marked (European Union).
- TRA Type Approved (United Arab Emirates).

QSM5 –

- WPC Type Approved (India).

QSM7 –

- FCC Compliant. Complies with the limits for a Class B digital device, pursuant to Part 15 of the FCC Rules (USA).

Environment

- Ambient Temperature Operating Range: 32 °F to 104 °F (0 °C to 40 °C).
- Relative humidity: less than 90% non-condensing.
- For indoor use only.

Terminals

- Input wiring: 22 AWG to 12 AWG (0.5 mm² to 4.0 mm²)
- QS link wiring: 22 AWG to 12 AWG (0.5 mm² to 4.0 mm²)

Mounting

- QSM units should be mounted in the middle of non-metal ceiling tile or drywall, visible from inside the space.
- Installation near metal other than a Junction Box may reduce RF range.

Wireless Communication

(models with wireless inputs only)

- RF Range: 60 ft (18 m) line of sight, or 30 ft (9 m) through typical construction materials.
- To ensure optimal wireless range, install the QSM in the ceiling in a visible position from inside the space.
- Lutron® Radio Powr Savr™ Occupancy sensor (up to 10)
- Lutron® Radio Powr Savr™ daylight sensor (up to 10)
- Lutron® Pico® wireless controllers (up to 10)

Wired Inputs

- There are 4 universal wired inputs. Each input can accept one of the following:
 - Lutron® EcoSystem® wallstations
 - Lutron® occupancy sensors (LOS- series)
 - Lutron® daylight sensors (EC-DIR- series)
 - Lutron® EcoSystem® infrared (IR) receivers (EC-IR, EC-DIR- series)
 - Lutron® Wired Pico® Controls
- Use of both the infrared receiver and daylight sensor on the EC-DIR- series sensors is considered two wired inputs on a QSM
- Maximum wiring distance = 150 ft (46 m)
- Only wired (LOS- series) and wireless occupancy sensors may be used in myRoom™; no Ecosystem® wallstations, daylight sensors, Ecosystem® IR receivers or wired Pico® controls

QS Link Limits

- The QS link can have up to 100 devices.
- Each QSM counts as 1 device towards the 100 device limit.
- Each QSM draws 3 Power Draw Units (PDUs) on the QS link.
- Wired sensors add to the PDU draw of a QSM. Refer to the QS Link Power Draw Units specification submittal (Lutron® P/N 369405) for information concerning PDUs.
- QS link maximum wire run length is 2000 ft (610 m).
- See the commercial system rules spec (P/N 369821) for system specific limitations.

Job Name:	Model Numbers:
Job Number:	

Mechanical Dimensions (All Models)

Front View

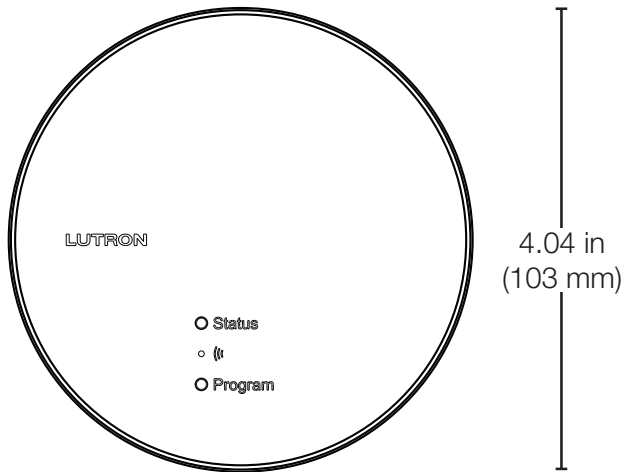

Side View

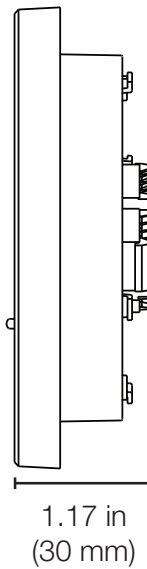

Back View

(QSM2-4W-C shown)

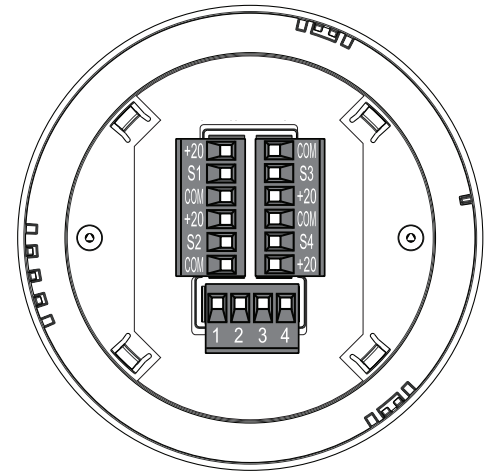

Mounted (-C Models)

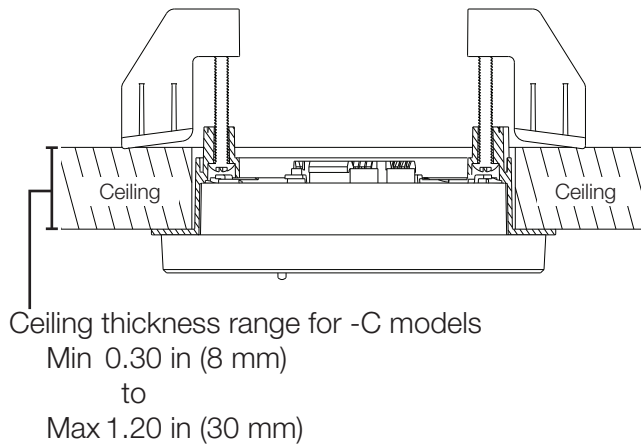

Mounted (-J Models)

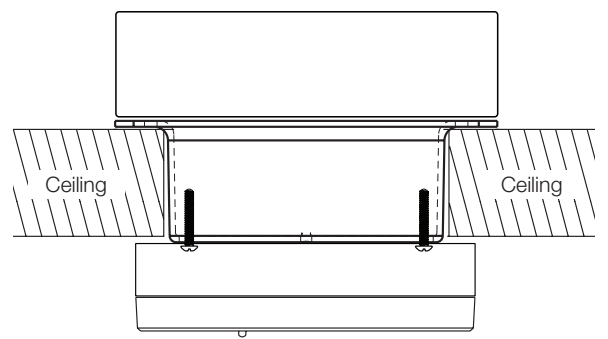

Use appropriate Mud Ring for ceiling tile thickness

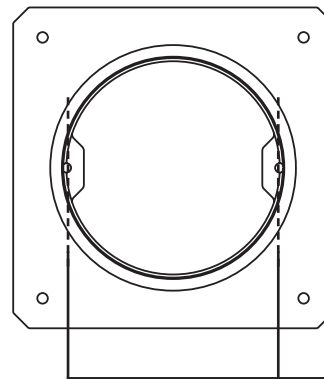

Use Mud Ring with hole spacing shown below. (Mud Ring not included with any QSM models)

Job Name:	Model Numbers:
Job Number:	

Wiring: QS Link and Wired Inputs¹

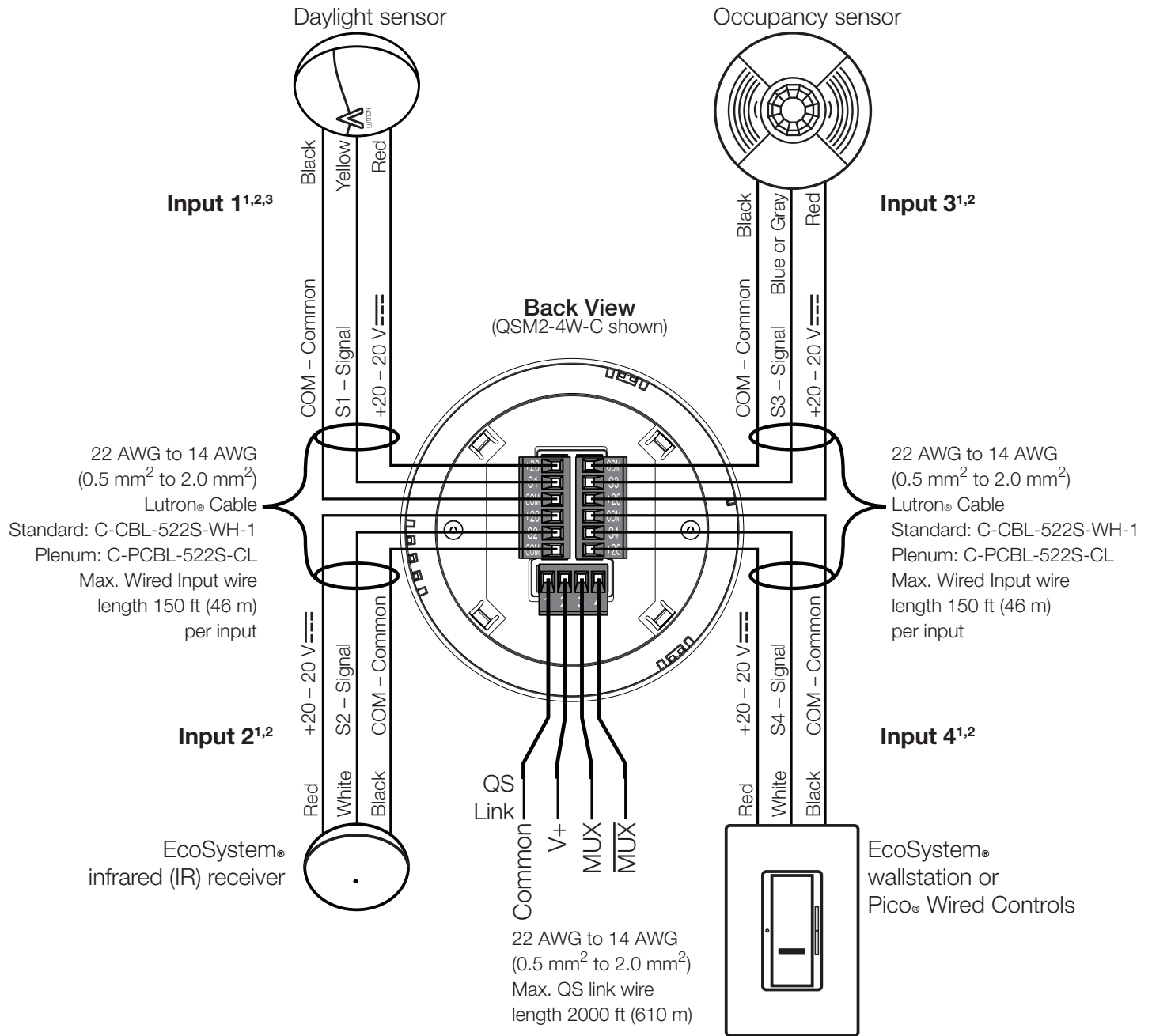

1 Only on QSM models with wired inputs.
 2 **Note:** For reference only. Each input is universal and can accept any of the inputs shown above.
 3 Only daylight sensor signal connected to QSM shown above. Use of IR signal counts as an additional input on the QSM.

LUTRON® SPECIFICATION SUBMITTAL		Page
Job Name:	Model Numbers:	
Job Number:		

Wiring: Device Power

Single QSM powered by an ESN unit

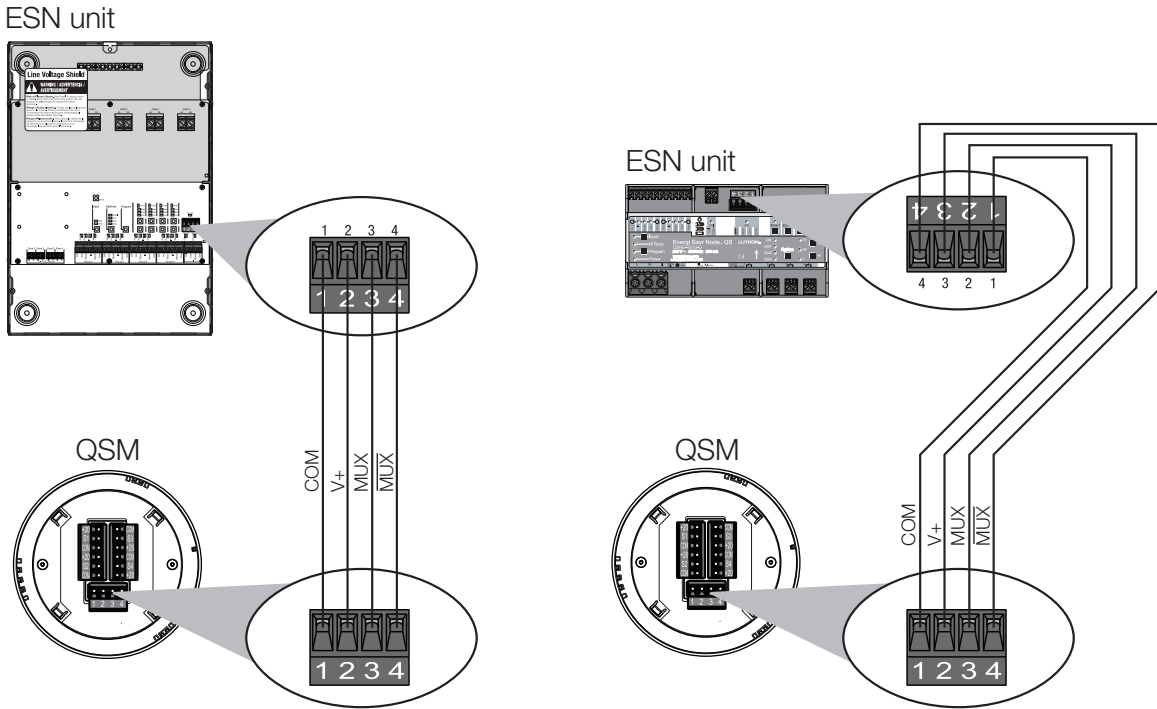

Multiple QSMs powered by an ESN unit and a QS Link Power Supply

Note: A QS Link Power Supply may be necessary if PDUs required by QSMs exceed available PDUs from the device supplying power.

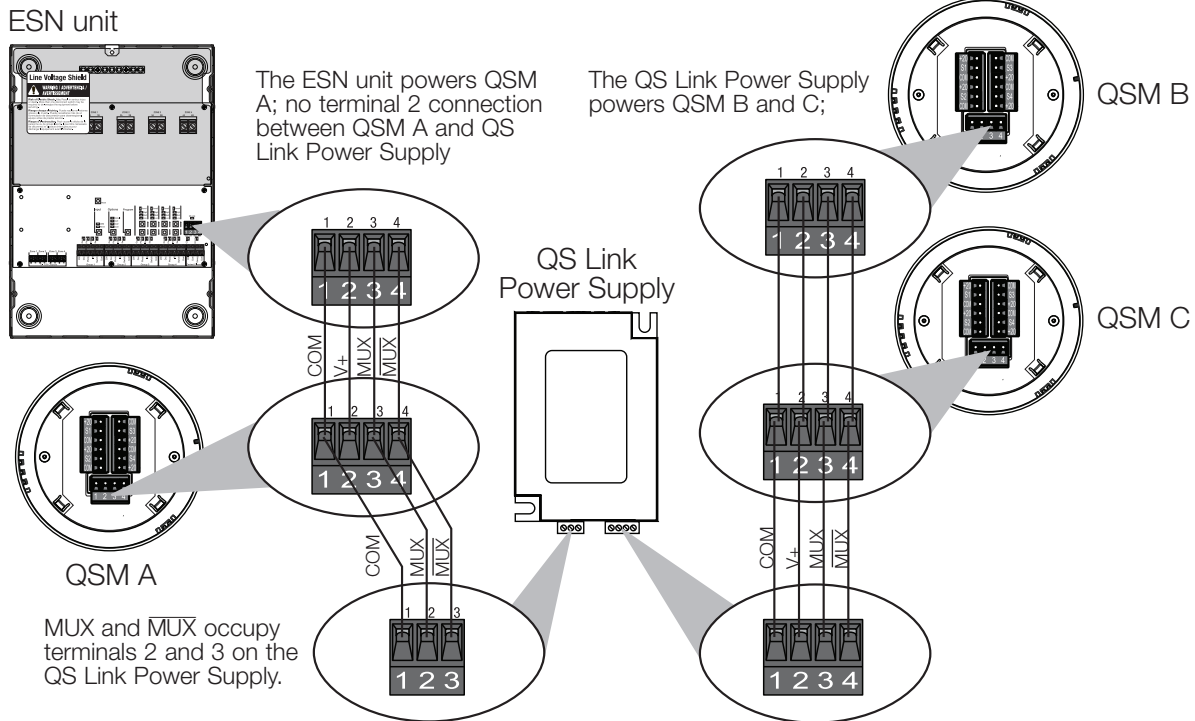

Job Name:	Model Numbers:
Job Number:	