



TRU-SINE SPS Series

PURE SINE WAVE MICRO INVERTERS 55-220 WATTS



PROJECT: _____
 FIXTURE TYPE: _____
 LOCATION: _____
 CONTACT/PHONE: _____

Pure Sine Wave micro inverter systems for powering up to 220 Watts/250VA of incandescent, fluorescent, induction or LED lighting loads. Pulse width modulated (PWM) output design provides clean, 60 Hz. sinusoidal emergency power to lighting loads. Models are available for surface, recessed or T-Grid mounting as required.

PRODUCT FEATURES

- Powers LED, induction, incandescent and fluorescent fixtures
- Sinusoidal output eliminates compatibility issues
- Universal 120/277VAC, 60Hz. input/output
- Unit capacities up to 220 watts/250 VA
- Soft Start design reduces fixture inrush current
- Install up to 1,000 feet from controlled fixture(s)
- Surface, recessed or T-Grid mount models
- Lumen output from fixture is 100% of nominal
- Unique design eliminates compatibility issues with LED drivers and fluorescent and induction ballasts
- Compatible with dimming ballasts
- Normally-on and/or Normally-off load output
- Provisions for local switching capability - Always on during emergency conditions regardless of local switch position
- Emergency fixtures can be on, off or switched
- Solid state, line latched low voltage disconnect provides protection against battery deep discharge
- Long life, maintenance-free lead-calcium battery
- Momentary test switch
- AC-On, Charge-On and Inverter-On LED indicators
- Meets NFPA Life Safety Code 101, OSHA, NEC, State and local Codes
- 90 Minute Runtime Minimum
- UL 924 listed



DIMENSIONS

Standard Surface Mount

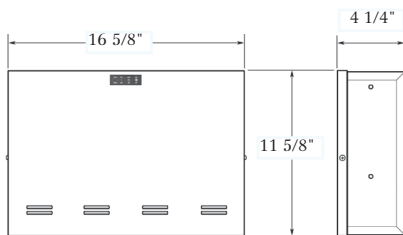

Optional Recessed Mount Housing

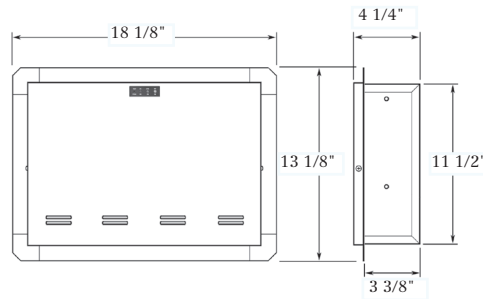

Optional Ceiling T-Grid Mount Housing

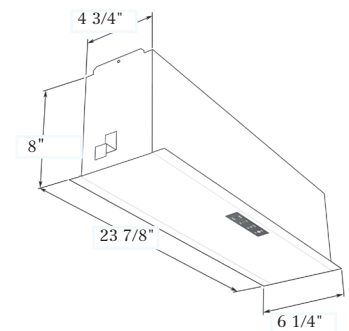

ORDERING INFORMATION

MODEL #	WATTS/VA RATING*	VOLTAGE	OPTIONS	DESCRIPTION
SPS	55/125	120/277	RMH	Recessed Mount Housing**
	110/125		TGRD	Plenum Rated T-Grid Mount**
	110/250		CC	Custom Housing Color
	220/250		4C	4 Output Circuit Switching

Ordering Example: SPS-110/125-120/277-R

*CAPACITY FOR 90 MINUTES

**AVAILABLE WITH SPS-55/125 AND SPS-110/125 MODELS ONLY



TRU-SINE SPS Series

PURE SINE WAVE MICRO INVERTERS 55-220 WATTS



PROJECT: _____
 FIXTURE TYPE: _____
 LOCATION: _____
 CONTACT/PHONE: _____

APPLICATION

The SPS Series is designed to provide up to 220watts/250VA of emergency power to LED, Induction, Fluorescent and/or incandescent light fixtures. The SPS unit provides clean, sinusoidal AC output power allowing it to be remotely mounted up to 1,000 feet away from the controlled fixture(s). Unlike a fluorescent emergency ballast, the SPS provides power to the input side of the fixture (including the ballast) eliminating any chance of incompatibility. The SPS Series is designed primarily for surface mounting, however, the SPS-55/125 and SPS-110/125 models provide optional housings for recessed or ceiling T-Grid mounting if required. All SPS systems will provide emergency power output for a minimum of 90 minutes.

CONSTRUCTION

The SPS Series housing is constructed of heavy duty steel cabinet that is finished with a white baked-on powder paint providing scratch and corrosion resistance. Optional color finishes are available, consult factory.

MOUNTING

SURFACE MOUNT: (STANDARD MODELS)

Surface mount models are designed for mounting to walls by means of keyhole slots provided in the rear of the unit housing.

RECESSED MOUNT: (SPS-55/125 and SPS-110/125 ONLY)

Recessed models provide a trim flange and recessed mounting holes on both sides of the enclosure.

T-GRID MOUNT: (SPS-55/125 and SPS-110/125 ONLY)

The housing design allows for simple drop-in installation between standard T-Grid runs. Safety wires (supplied by others) are required for attachment to building structure.

GENERAL SPECIFICATIONS

MODEL #	SYSTEM EFFICIENCY	# OF BATTERIES	BATTERY VOLTAGE (VDC)	BATTERY CURRENT (AMPS)
SPS-55/125	98%	2	24	3.4
SPS-110/125	98%	2	24	5.7
SPS-110/250	98%	4	48	3.3
SPS-220/250	98%	4	48	5.6

WIRING

Connection to an unswitched AC circuit is required by the NEC. Wiring access is provided for by conduit knockouts in the unit housing. SPS-55/125 and SPS-110/125 models also provide knockouts in the back of the housing for rear wiring from standard electrical boxes when surface mounting.

LOAD COMPATIBILITY

SPS model's clean, sinusoidal AC output will operate incandescent lamps as well as all common fluorescent, induction and LED lamp types. Lighting loads are driven at 100% output for the entire emergency power cycle. This outstanding feature translates into greater occupant egress vision and safety.

CODE COMPLIANCE

All models are UL924 Listed and meet NFPA 101 Life Safety Code, NEC, OSHA, Local and State Codes. Optional T-Grid models are plenum rated.

OPERATION

Upon failure of the normal utility power the SPS unit is automatically turned on by a solid-state switching circuit and provides a minimum of 90 minutes of emergency power to the connected load. Lumen output will be maintained at 100% of the lamps rating throughout the entire duration. A solid-state low voltage disconnect circuit is used to protect the battery from being severely damaged by a deep discharge. When normal utility power is restored, the unit switches the load back to normal utility operation and the fully automatic, temperature compensated, dual mode charger begins to restore the battery; bringing it to full charge within UL924 specified parameters. A brownout sensing circuit insures proper operation during "low line" conditions.



TRU-SINE SPS Series

PURE SINE WAVE MICRO INVERTERS 55-220 WATTS



PROJECT:	_____
FIXTURE TYPE:	_____
LOCATION:	_____
CONTACT/PHONE:	_____

ELECTRICAL

Input

Input Voltages: (60Hz) 120 or 277VAC ± 10%

Input Frequencies: 60Hz ± 2%

Input Protection: AC Line Fuses

Output

Output Voltages: (60Hz) 120 or 277VAC

Efficiency Rating: 98% at full rated load (line)

Waveform: Sinusoidal (digitally controlled)

Static Voltage: ± 5% during battery discharge. 0-100% linear load.

Output Frequencies: 60 Hz. ± 0.3Hz during emergency cycle

Output Distortion: Less than 3% THD (linear load)

Transfer Time: Less than 1.0 second

Load Power Factor Range: 0.44 Lead to 0.44 Lag

Minimum Loading: 0% of rated system capacity

Output Protection: Line and inverter fuses

IMPROVED AESTHETICS

The SPS system's sinusoidal AC output design eliminates voltage drop and proximity concerns. This allows added flexibility in installation location as SPS units can be installed hundreds of feet from the units they power. This means SPS units to be located conveniently out of sight in closets or utility rooms without interrupting architectural aesthetics. In lighting applications, no special or additional emergency fixtures are necessary. Simply designate and connect existing lighting fixtures, either interior or exterior, to the SPS unit for emergency operation eliminating the need for exposed, stand-alone emergency luminaires.

WARRANTY

Unit: 3-years full coverage against defects in materials and workmanship from date of shipment

Battery: 3 years full warranty plus an additional 7 years of pro-rata coverage

BATTERIES & CHARGER

Battery

Battery: Sealed Lead Calcium (10 year life)

Battery Voltage: 24VDC for SPS-55/125,

SPS-110/125 models and 48VDC for SPS110/250, SPS220/250 models

Runtime: 90 minutes standard - based on battery performance at 77°F (25°C).

Other runtimes available, consult factory.

Battery Protection: Low Voltage Battery Disconnect protects the battery from being severely

damaged by deep discharge during prolonged power failures.

DC Overload and Short Circuit Protection provided by a DC input breaker and fuse.

Charger

Charger Type: Fully automatic, temperature compensated, dual-mode charger

Power Consumption (Charger Only):

15W maximum (2.5W in standby) for SPS-55/125, and SPS-110/125 models

30W maximum (2.5W in standby) for SPS110/250, and SPS220/250 models

Recharge Duty Cycle: Meets UL924 requirements

Battery Circuit Breaker: Also used as battery isolator

Controls: Momentary test switch, AC-On,

Charge-On and Inverter-On LED indicator lights

Safety Circuitry: AC Lockout prevents battery discharge prior to initial unit power-up.

Brownout Protection automatically switches the unit to emergency mode when utility voltage is significantly reduced.

Environmental

Altitude: < 10,000 feet (3,000m) above sea level without derating.

Operating Temperature Range: 68°F to 86°F (20°C to 30°C)

NOTE: Optimum system performance between 20°C (68°F) and 30°C (86°F); temperatures outside of this range will affect battery performance and life.

Relative Humidity: 95% non-condensing