

SN 80 Low Profile Intermediate Fan



Description

Low Profile quiet ventilation fan with high efficiency, capacitor start motor. Energy Star and HVI 2100 certified, ETL listed, conforms to UL 507 safety standards. ETL listed for installation above bath or shower with GFCI protected circuit breaker. Suited for use in bathrooms, spa's, laundry rooms, and other damp locations.

Housing

Made of rugged 26 GA galvanized steel for superior corrosion resistance. Detachable 4" polymer duct adapter with "noiseless" back draft damper. Twin bar-hanger mounting brackets adjust from 13-3/4 to 25" inches for ideal positioning between ceiling members. Housing Dimensions: Width 10-1/2", Length 11-3/8", Height 5-5/8" and fits between floors with 2 x 6 joist construction. IC Rated for direct contact with insulation up to R40. Integral four (4) point mounting bracket allows housing to be attached directly to ceiling joist without the use of bar-hangers. Can be mounted in sloped ceilings up to 12-12 pitch (45 degrees).

Blower motor

Very efficiency, split capacitor, permanently lubricated motor with quick disconnect plug. Energy Star certified and engineered for continuous operation with built in overload protection to insure longer motor life: 120 Volts / 60 Hz. One-piece blower and motor assembly can be easily removed and replaced from below the ceiling. Four (4) isolation dampeners provide ultra quiet operation with minimal vibration transfer.

Grille

Attractive, low profile, high impact grille made with premium UV inhibited polymer resin. Powerful torsion springs seat the grille tightly and evenly to the ceiling surface. Grille can be attached or removed without the use of tools. Grille dimensions: 13-3/4 X 13".

CFM	80
SONES	1.1
HEIGHT	5-5/8"
DUCT	4"



SN-80 Series

- Very Quiet: 1.1 sones
- 5-5/8" Height, ideal for 2x6 const.
- 120 volt / 60 Hz
- Galvanized Housing
- Adjustable bar hangers 14-24"
- 4" duct adapters included
- Integral direct mounting bracket
- High efficiency "no lube" motor
- ETL listed
- Energy Star approved
- HVI 2100 certified
- Title 24 Ready
- Conforms to UL standard 507
- IC Rated up to R40 insulation

24" bar hangers included, mount in sloped ceilings up to 12/12 pitch

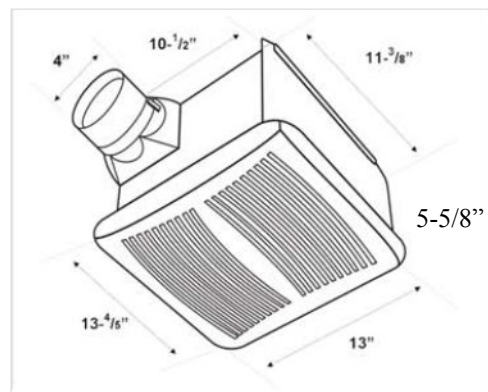
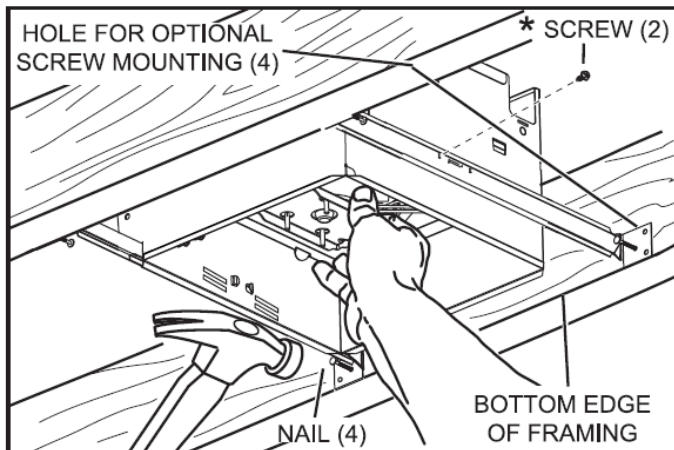



Ultimate Ventilation Solutions

SN 80 Low Profile Intermediate Fan

Specification Data

Model Number	SN80					
Static Pressure in inches w.g.	0.1	0.25				
Air Volume (CFM)	80	63				
Noise (Sones) 4" Duct	1.1 s	n/a				
Fan Watts	26 w	26 w				
Power (Volts / Hertz)	120v 60hz					

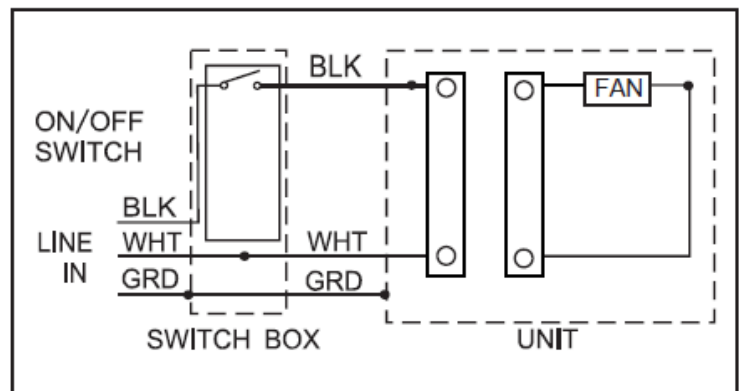
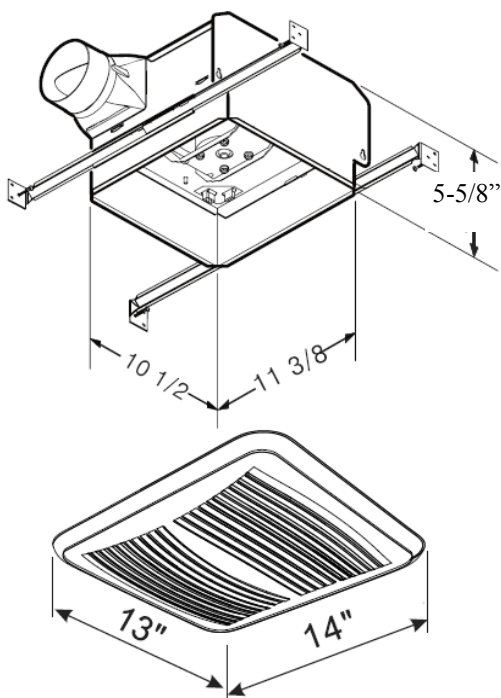

CERTIFICATIONS

