

Type \_\_\_\_\_

-80

P4537

P4539

Catalog No.	Finish	Lamping	Dimensions (Inches)		
	Forged Black		A	B	C
P4537	-80	3 (c) 60w	25	20	86
P4539	-80	5 (c) 60w	30	23	89

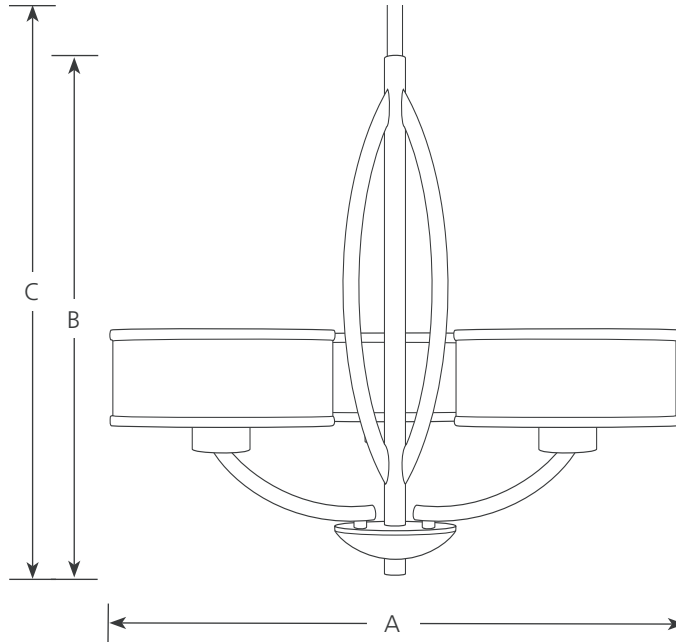

**Specifications:**

General

- Fabric glass shades with etched glass diffuser on bottom
- Painted forged black (-80) finish
- Steel construction
- Two 6", one 12", two 15" stems and six links of chain included
- Companion fixtures: Hall and foyer, chandeliers, pendants, wall brackets, close to ceiling, and bath and vanity

Mounting

- Ceiling stem mount with chain
- Covers outlet box
- Canopy covers a standard recessed 4" octagonal outlet box
- Mounting strap for outlet box included

Electrical

- Pre-wired
- 10 feet of wire
- Phenolic candelabra sockets

Labeling

- cCSAus listed