

PST154T5IVCD

Ballast Type:	Electronic	Starting Method:	Programmed Start	Unit Weight:	0.79 lb.
Input Voltage:	100 thru 277VAC ±10%	Lamp Connection:	Series	Carton Quantity:	36
Input Frequency:	50/60 Hz.	Unit Color:	White	Skid Quantity:	1296

ELECTRICAL SPECIFICATION:

Lamp Type	Lamp Watts	No. of Lamps	Line Voltage (V)	Line Current (A)	Input Power (W)	Power Factor	Max Current THD (%)	Current Crest Factor	Ballast Factor	B.E.F.	Dimmer Setting
F54T5HO	54	1	120	0.50	59	≥0.99	≤10	≤1.4	1.00	1.69	Maximum
			277	0.23	58	≥0.92	≤20			1.67	
			120	0.08	9	≥0.92	≤20	≤1.7	0.05	0.56	Minimum
			277	0.07		≥0.50	≤25				
FT55W/2G11/RS	55	1	120	0.48	55	≥0.99	≤10	≤1.4	0.92	1.67	Maximum
			277	0.21	54	≥0.92	≤20			1.70	
			120	0.08	8	≥0.92	≤20	≤1.5	0.04	0.50	Minimum
			277	0.07		≥0.50	≤30				
FT50W/2G11/RS	50	1	120	0.50	60	≥0.99	≤10	≤1.4	1.10	1.83	Maximum
			277	0.23	58	≥0.92	≤20			1.90	
			120	0.09	11	≥0.95	≤20	≤1.5	0.06	0.55	Minimum
			277	0.07		≥0.50	≤30				

CASE STYLE: 19D

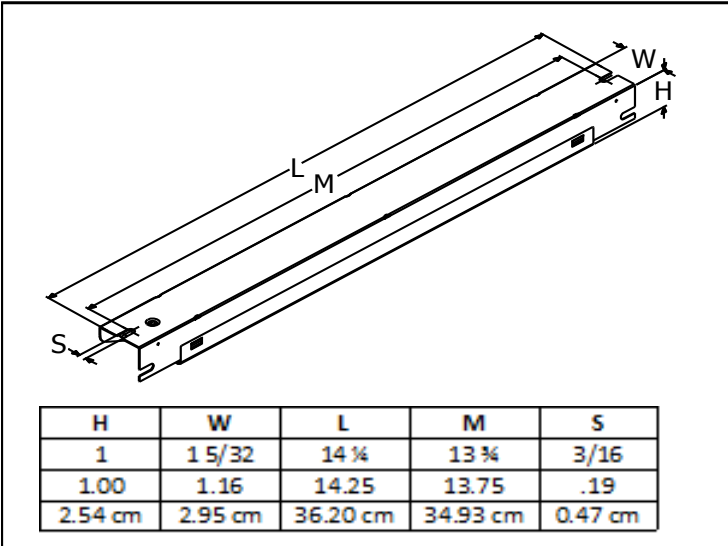

WIRING DIAGRAM: 043

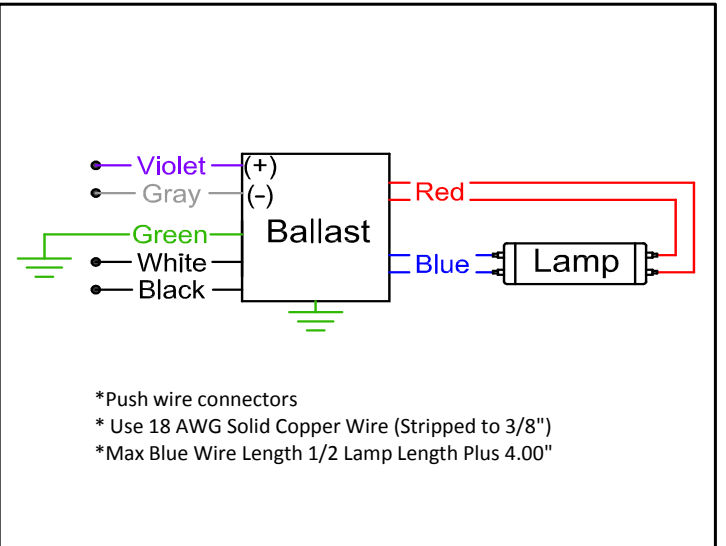

PST154T5IVCD

PERFORMANCE:

- High frequency electronic dimming ballast
- Programmed start
- Series lamp operation
- High power factor
- Sound rated A
- End of lamp life protection with auto restart after lamp replacement
- Analog dimming control 1-10VDC
- Class 1 or Class 2 wiring for ballast control circuit
- Dimming range 100% - 10% relative light output
- Lamps will start at any dimming level without flicker
- Dimming control circuit protected from line voltage
- Internal surge protection
- Meets FCC Part 18 (Class B) for EMI and RFI consumer limits
- Meets CE requirements (120-240V)
- Meets ANSI standard C82.11 where applicable
- Meets ANSI standard C62.41
- EN60929:2006; A.C. supplied electronic ballasts for tubular fluorescent lamps/performance requirements
- EN61347-1:2008; Lamp controlgear/general safety requirements
- EN 61347-2-3:2001 +A1:2004 +A2:2006; Lamp controlgear/particular requirements for A.C. supplied electronic ballasts for fluorescent lamps
- EN61547:1996 +A1:2000; Specification for Equipement for General Lighting Purposes
- EN55015:2006 (CISPR 15); Limits and methods of measurement of radio disturbance characteristics of electrical lighting and similar equipment
- EMC Requirements Per IEC Publication 6100 Electromagnetic Compatibility (EMC):
- EN6100-3-2:2006 Part 3: Limits-Section2: Limits for harmonic current emissions
- EN 61000-3-3: 1995, A1: 2001 +A2:2005 Electromagnetic Compatibility Part 3 Limits – Section 3: Limitation of voltage fluctuations and flicker in low voltage supply systems for equipment with rated current up to 16 amps.

APPLICATION:

- Maximum case temperature: 167°F/75°C
- Maximum ambient temperature: 104°F/40°C
- Minimum starting temperature: 50°F/10°C†
- Lamp starts: >50,000 starts
- Mount lamps within 1/4" of ground plane
- Remote mounting: 2 ft.

SAFETY:

- UL/935 (Class P, Type HL, Type CC) listed
- CSA certified (cUL)
- RoHS Compliant
- No PCB's

WARRANTY:

Robertson Worldwide warrants to the purchaser that this ballast will be free from defects in material or workmanship for a period of 3 years from date of manufacture when properly installed and under normal conditions of use. For more information on Robertson Worldwide's ballasts, call 1-800-323-5633 or visit www.robertsonww.com. Specifications subject to change without notice.

12/19/2011